

## Linksgjenget muffe

DIN 16283  
G1/2" x G1/2" LH  
SW / AF 27

G1/2  
ISO 228

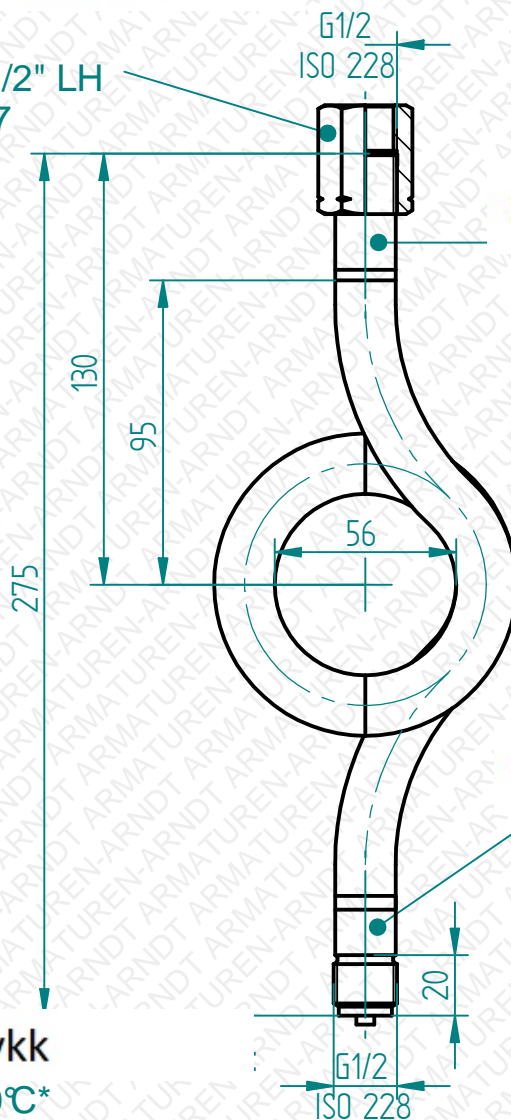

Sveiset rørforbindelse

DIN 16282, Form 6, G1/2" LH

Sveiset rørforbindelse

DIN 16282, Form 4, G1/2"

Utvendig gjenge

DIN EN 837-1

Driftstrykk

- max. 160bar / 120°C\*
- max. 120bar / 300°C\*
- max. 100bar / 400°C\*

Toleranse bredde +/- 5 mm

\* Temperaturbarriere

Med forbehold om endring

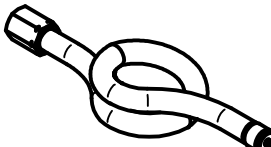
Manometer accessories		Dato	Navn	Skala	Material
		03.01.2017	Nanko	1:2	1.4571 / 316Ti
Tolerances according to DIN ISO 2678 part 1 & 2		Fig. 96 Dampsløyfe DIN 16282, form C G1/2"			
		10096043			



Øvre-Johnsen as

Øvre-Johnsen AS

Øvre Flatåsveg 16, 7079 Flatåsen

Tlf: 72 59 61 00



Zertifiziert nach DIN EN ISO 9001