

Data sheet

APP Pumps

APP 0.6-1.0 / APP 1.5-3.5 /
APP (W) 5.1-10.2 / APP 11-13 /
APP 16-22 / APP 21-43



Table of Contents
Contents

1.	Introduction	3
2.	Benefits.....	3
3.	Application examples	3
4.	Technical data	4
4.1	APP 0.6-1.0.....	4
4.2	APP 1.5-3.5.....	5
4.3	APP (W) 5.1-10.2.....	6
4.4	APP 11-13	7
4.5	APP 16-22.....	8
4.6	APP 21-30.....	9
4.7	APP 38-43.....	10
5.	Flow at different rpm.....	11
5.1	APP 0.6-1.0 flow curves measured at 80 barg (1160 psig)	11
5.2	APP 1.5-3.5 flow curves at 80 barg (1160 psig)	12
5.3	APP (W) 5.1-10.2 flow curves at 80 barg (1160 psig)	13
5.4	APP 11-13 flow curves at 60 barg (870 psig)	14
5.5	APP 16-22 flow curves at 60 barg (870 psig)	15
5.6	APP 16-22 flow curves at 60 barg (870 psig)	16
5.7	APP 21-30 flow curves at 60 barg (870 psig)	17
5.8	APP 21-38 flow curves at 60 barg (870 psig)	18
5.9	APP 43 flow curves 60 barg (870 psig)	19
6.	Flushing valve curves	20
6.1	APP 0.6-1.0 integrated flushing valve	20
6.2	APP 1.5-3.5 integrated flushing valve	20
6.3	APP 5.1-10.2 Flushing valve not available.....	21
6.4	APP 11-13 integrated flushing valve	21
6.5	APP 16-22 integrated flushing valve	21
6.6	APP 21-43 integrated flushing valve	22
7.	Motor requirements.....	23
7.1	Calculation factor for APP 0.6-1.0	23
7.2	Calculation factor for APP 1.5-3.5	23
7.3	Calculation factor for APP (W) 5.1-10.2	23
7.4	Calculation factor for APP 11-13.....	23
7.5	Calculation factor for APP 16-22	23
7.6	Calculation factor for APP 21-43	23
8.	Temperature and corrosion.....	24
8.1	Operation.....	24
9.	Installation.....	24
9.1	Filtration	25
9.2	RO system with direct supply:	25
10.	Dimensions and connections.....	27
10.1	APP 0.6-1.0.....	27
10.2	APP 1.5-3.5.....	28
10.3	APP (W) 5.1-10.2.....	29
10.4	APP 11-13	30
10.5	APP 16-22.....	31
10.6	APP 21-43.....	32
11.	Dimensions with motor unit.....	33
11.1	APP 0.6-3.5.....	33
11.2	APP (W) 5.1-10.2.....	34
11.3	APP 11.0-13.0.....	35
11.4	APP 16.0-22.0	36
11.5	APP 21.0-38.0	37
11.6	APP 43	38
12.	Accessories	39
12.1	Accessories for APP (W) 5.1-10.2	39
12.2	Accessories for APP 11-13	39
12.3	Accessories for APP 16-22	39
12.4	Accessories for APP 21-43	39
13.	Service.....	40

Data sheet | APP 0.6-43 / APP (W) 5.1-10.2 pumps

1. Introduction

This data sheet is valid for APP pumps both non ATEX and ATEX certified. ATEX certified pumps are indicated by Ex in the type designation - example APP 0.6 Ex.

The Danfoss range of APP high-pressure pumps is designed according to EN 809 for use in RO applications with low viscosity and corrosive fluids such as:

- Sea water
- Brackish water
- Waste water (APP W)

Danfoss APP pumps are positive displacement pumps with axial pistons that move a fixed amount of water in each cycle. Flow is proportional to the number of input shaft revolutions (rpm). Unlike centrifugal pumps, they produce the same flow at a given speed no matter what the discharge pressure.

Below sectional drawing is an example of an APP pump. The sectional drawing for the specific pump sizes are to be found in the pump instruction.

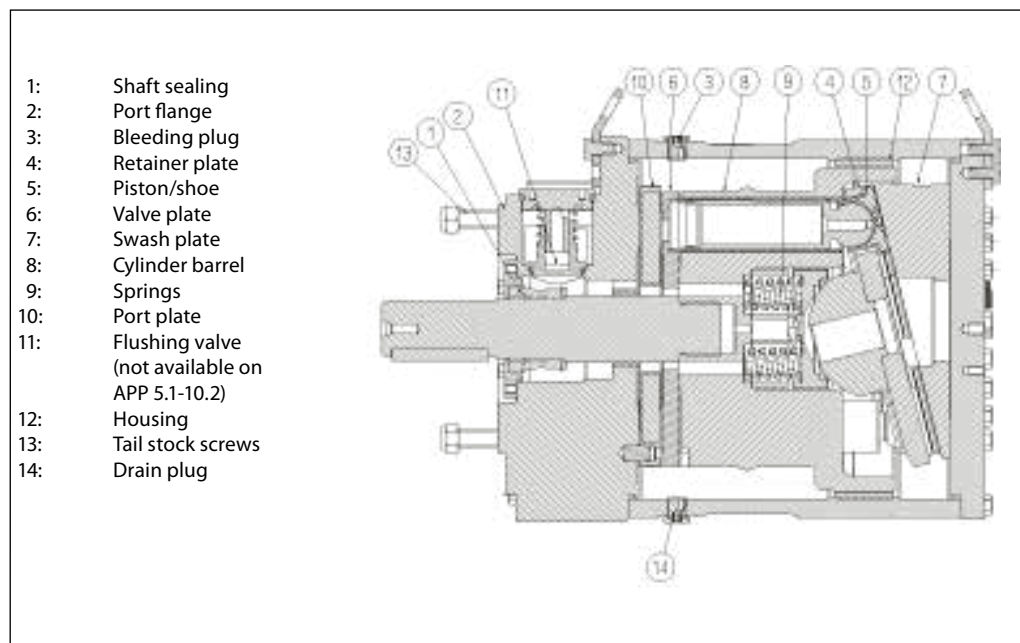

2. Benefits

- **Zero risk of lubricant contamination:**
 - Oil lubricants are replaced with the pumped medium, water, so there is no contamination risk from the pump.
- **Low maintenance costs:**
 - Efficient design and all-stainless steel construction ensure exceptionally long life. When Danfoss specifications are met, service intervals of 8,000 hours can be expected. Service is easy, and can be carried out on-site due to the simple design and few parts.
- **Low energy costs:**
 - The highly efficient axial piston design provides the lowest energy consumption of any comparable pump on the market.
- **Easy installation:**
 - The most compact and lightest design available.
 - The pump can be installed vertically and horizontally.
 - No pulsation dampeners necessary due to extremely low pressure pulsation.
- **Powered directly by electric motors or combustion engines (with special coupling).**
- **All pumps except APP (W) 5.1 - 10.2 are supplied with an integrated flushing valve that allows the fluid to flow from inlet to the outlet, when the pump is not running.**
- **High reliability:**
 - All parts are made of high corrosion resistant materials e.g. Duplex (EN1.4462/ UNS S31803/SAF 2205) and Super Duplex (EN1.4410/UNS S32750/ SAF 2207) stainless steel and carbon reinforced PEEK.
- **Certified quality:**
 - Pump available as ATEX certified: category 2, zone 1 or category 3, zone 2. For other certifications, please see data sheets for APP S (all super duplex) and APP S 674 (API).
 - Positive Material Identification (PIM) report available on request.
 - ISO 9001, ISO 14001.

3. Application examples

Danfoss APP pumps are built into a broad range of RO desalination plants around the world:

- Containerized solutions for hotels, resorts and residences on islands and in coastal regions
- Mobile systems for humanitarian and military organizations
- Onboard systems for ships and yachts
- Offshore platforms for the oil and gas industry
- Municipal and regional waterworks

4 Technical data
4.1 APP 0.6-1.0

Pump size		APP 0.6	APP 0.8	APP 1.0
Code number APP		180B3048	180B3037	180B3049
Code number APP ATEX ⁴⁾		180B3148	180B3137	180B3149
Geometric displacement	cm ³ /rev.	4.07	5.08	6.30
	in ³ /rev.	0.25	0.31	0.38
Pressure				
Max. outlet ¹⁾ pressure continuous	barg	80	80	80
	psig	1160	1160	1160
Min. outlet ¹⁾ pressure	barg	20	20	20
	psig	290	290	290
Inlet pressure ²⁾ continuous	barg	0.5 - 5	0.5 - 5	0.5 - 5
	psig	7.3 - 72.5	7.3 - 72.5	7.3 - 72.5
Max. inlet pressure peak	barg	10	10	10
	psig	145	145	145
Speed				
Min. speed continuous	rpm	700	700	700
Max. speed ²⁾ continuous	rpm	3450	3450	3450
Typical flow - Flow curves available in item 5				
1000 rpm at max. pressure	m ³ /h	0.22	0.29	0.36
1500 rpm at max. pressure	m ³ /h	0.34	0.43	0.54
1200 rpm at max. pressure	gpm	1.18	1.52	1.90
1800 rpm at max. pressure	gpm	1.78	2.28	2.84
Technical specifications				
Media ³⁾ temperature	°C	2 - 50	2 - 50	2 - 50
	°F	36 - 122	36 - 122	36 - 122
Ambient temperature	°C	0-50	0-50	0-50
	°F	32 - 122	32 - 122	32 - 122
Weight (dry)	kg	5.2	5.2	5.2
		11.5	11.5	11.5
Sound pressure level, LPA 1m ⁵⁾	dB(A)	74	74	74
Footprint with IEC motor ⁶⁾	m ²	0.1	0.1	0.14
	foot ²	1.08	1.08	1.51
Typical motor size				
Max. speed at max. pressure	kW	2.2	3.0	4.0
3000 rpm at max. pressure	HP	3	5	5
Torque at max. outlet pressure	Nm	5.8	7.2	8.9
	lbf-ft	4.2	5.3	6.6

¹⁾ For lower and higher pressure, please contact Danfoss.

²⁾ For speeds above 3000 rpm the pump must be boosted at a pressure of 2-5 barg (29- 72.5 psig).

³⁾ Dependent on the NaCl concentration - see chapter 8.

⁴⁾ Category 2, Zone 1 or Category 3, Zone 2.

⁵⁾ A-weighted sound pressure level at 1 m from the pump unit surfaces (reference box) acc. to EN ISO 20361 section 6.2. The noise measurements are performed acc. to EN ISO 3744:2010 on a motor-pump unit at max. pressure and speed.

⁶⁾ Max. area covered with recommended motor configuration (excl. of space to service pump)

4.2 APP 1.5-3.5

Pump size		APP 1.5	APP 1.8	APP 2.2	APP 2.5	APP 3.0	APP 3.5
Code number APP		180B3043	180B3044	180B3045	180B3046	180B3030	180B3032
Code number APP ATEX ⁴⁾		180B3143	180B3144	180B3145	180B3146	180B3130	180B3132
Geometric displacement	cm ³ /rev.	9.31	10.04	12.52	15.35	17.70	20.54
	in ³ /rev.	0.57	0.61	0.76	0.94	1.08	1.25
Pressure							
Max. outlet ¹⁾ pressure continuous	barg	80	80	80	80	80	80
	psig	1160	1160	1160	1160	1160	1160
Min. outlet ¹⁾ pressure	barg	20	20	20	20	20	20
	psig	290	290	290	290	290	290
Inlet pressure continuous	barg	0.5 - 5 ²⁾	0.5 - 5 ²⁾	0.5 - 5 ²⁾	0.5 - 5	0.5 - 5 ²⁾	0.5 - 5
	psig	7.3 - 72.5 ²⁾	7.3 - 72.5 ²⁾	7.3 - 72.5 ²⁾	7.3 - 72.5	7.3 - 72.5 ²⁾	7.3 - 72.5
Max. inlet pressure peak	barg	10	10	10	10	10	10
	psig	145	145	145	145	145	145
Speed							
Min. speed continuous	rpm	700	700	700	700	700	700
Max. speed continuous	rpm	3450 ²⁾	3450 ²⁾	3450 ²⁾	3000	3450 ²⁾	3000
Typical flow - Flow curves available in item 5							
1000 rpm at max. pressure	m ³ /h	0.53	0.57	0.73	0.90	1.02	1.19
1500 rpm at max. pressure	m ³ /h	0.79	0.86	1.09	1.34	1.54	1.79
1200 rpm at max. pressure	gpm	2.80	3.03	3.83	4.73	5.41	6.30
1800 rpm at max. pressure	gpm	4.19	4.55	5.75	7.09	8.12	9.46
Technical specifications							
Media ³⁾ temperature	°C	2 - 50	2 - 50	2 - 50	2 - 50	2 - 50	2 - 50
	°F	36 - 122	36 - 122	36 - 122	36 - 122	36 - 122	36 - 122
Ambient temperature	°C	0 - 50	0 - 50	0 - 50	0 - 50	0 - 50	0 - 50
	°F	32 - 122	32 - 122	32 - 122	32 - 122	32 - 122	32 - 122
Weight (dry)	kg	8.6	8.6	8.6	8.6	8.6	8.6
	lb	17	17	17	17	17	17
Sound pressure level ⁵⁾	dB(A)	77	77	77	81	81	81
Footprint with IEC motor ⁶⁾	m ²	0.15	0.16	0.21	0.21	0.30	0.30
	foot ²	1.61	1.72	2.26	2.26	3.23	3.23
Typical motor size							
Max. speed at max. pressure	kW	5.5	5.5	7.5	7.5	11	11
3000 rpm at max. pressure	HP	7.5	7.5	10.0	15.0	15.0	15.0
Torque at max. outlet pressure	Nm	13.0	13.9	17.4	21.3	24.5	28.7
	lbf-ft	9.6	10.3	12.8	15.7	18.1	21.2

¹⁾ For lower and higher pressure, please contact Danfoss.

²⁾ For speeds above 3000 rpm the pump must be boosted at a pressure of 2-5 barg (29- 72.5 psig).

³⁾ Dependent on the NaCl concentration - see chapter 8.

⁴⁾ Category 2, Zone 1 or Category 3, Zone 2.

⁵⁾ A-weighted sound pressure level at 1 m from the pump unit surfaces (reference box) acc. to EN ISO 20361 section 6.2. The noise measurements are performed acc. to EN ISO 3744:2010 on a motor-pump unit at max. pressure and speed.

⁶⁾ Max. area covered with recommended motor configuration (excl. of space to service pump)

4.3 APP (W) 5.1-10.2

Pump size		APP (W) 5.1	APP (W) 6.5	APP (W) 7.2	APP (W) 8.2	APP (W) 10.2
Code number APP		180B3005	180B3006	180B3007	180B3008	180B3010
Code number APP ATEX ⁴⁾		180B3105	180B3106	180B3107	180B3108	180B3110
Code number APP W		180B3075	180B3076	180B3077	180B3078	180B3080
Geometric displacement	cm ³ /rev.	50.2	63.3	70.3	80.4	100.5
	in ³ /rev.	3.06	3.86	4.29	4.91	6.13
Pressure						
Max. outlet ¹⁾ pressure continuous	barg	80	80	80	80	80
	psig	1160	1160	1160	1160	1160
Min. outlet ¹⁾ pressure	barg	20	20	20	20	20
	psig	290	290	290	290	290
Inlet pressure ²⁾ continuous	barg	0.5 - 5	0.5 - 5	0.5 - 5	0.5 - 5	0.5 - 5
	psig	7.3 - 72.5	7.3 - 72.5	7.3 - 72.5	7.3 - 72.5	7.3 - 72.5
Max. inlet pressure peak	barg	5	5	5	5	5
	psig	72.5	72.5	72.5	72.5	72.5
Speed						
Min. speed continuous	rpm	700	700	700	700	700
Max. speed ²⁾ continuous	rpm	1800	1800	1800	1800	1800
Typical flow - Flow curves available in item 5						
1000 rpm at max. pressure	m ³ /h	2.79	3.57	4.01	4.62	5.83
1500 rpm at max. pressure	m ³ /h	4.19	5.36	6.01	6.93	8.75
1200 rpm at max. pressure	gpm	14.75	18.87	21.16	24.39	30.82
1800 rpm at max. pressure	gpm	22.13	28.31	31.74	36.59	46.23
Technical specifications						
Media ³⁾ temperature	°C	2 - 50	2 - 50	2 - 50	2 - 50	2 - 50
	°F	35.6 - 122	35.6 - 122	35.6 - 122	35.6 - 122	35.6 - 122
Ambient temperature	°C	0 - 50	0 - 50	0 - 50	0 - 50	0 - 50
	°F	32 - 122	32 - 122	32 - 122	32 - 122	32 - 122
Weight (dry)	kg	30	30	30	30	30
	lb	66	66	66	66	66
Sound pressure level ⁵⁾	dB(A)	78	78	78	78	78
Footprint with IEC motor ⁶⁾	m ²	0.32	0.33	0.33	0.35	0.43
	foot ²	3.44	3.55	3.55	3.77	4.63
Typical motor size						
Max. speed at max. pressure	kW	15.0	18.5	22	22	30
1200 rpm at max. pressure	HP	20	20	20	20	25
Torque at max. outlet pressure	Nm	70	81	98	112	141
	lbf-ft	52	65	73	83	104

¹⁾ For lower and higher pressure, please contact Danfoss.

²⁾ For speeds above 1500 rpm the pump must be boosted at a pressure of 2-5 barg (29- 72.5 psig).

³⁾ Dependent on the NaCl concentration - see chapter 8.

⁴⁾ Category 2, Zone 1 or Category 3, Zone 2.

⁵⁾ A- weighted sound pressure level at 1 m from the pump unit surfaces (reference box) acc. to EN ISO 20361 section 6.2. The noise measurements are performed acc. to EN ISO 3744:2010 on a motor-pump unit at max. pressure and speed.

⁶⁾ Max. area covered with recommended motor configuration (excl. of space to service pump)

4.4 APP 11-13

Pump size		APP 11/1200	APP 11/1500	APP 13/1200	APP 13/1500
Code number APP		180B3212	180B3211	180B3214	180B3213
Code number APP ATEX ³⁾		180B3222	180B3221	180B3224	180B3223
Geometric displacement	cm ³ /rev.	166.4	137.4	197.5	166.4
	in ³ /rev.	10.15	8.38	12.05	10.15
Pressure					
Max. outlet ¹⁾ pressure continuous	barg	80	70	80	70
	psig	1160	1015	1160	1015
Min. outlet ¹⁾ pressure	barg	10	10	10	10
	psig	145	145	145	145
Inlet pressure continuous	barg	2 - 5	2 - 5	2 - 5	2 - 5
	psig	29 - 72.5	29 - 72.5	29 - 72.5	29 - 72.5
Max. inlet pressure. peak	barg	10	10	10	10
	psig	145	145	145	145
Speed					
Min. speed continuous	rpm	700	700	700	700
Max. speed continuous	rpm	1200	1500	1200	1500
Typical flow - Flow curves available in item 5					
1000 rpm at max. pressure	m ³ /h	9.22	7.50	11.07	9.23
1500 rpm at max. pressure	m ³ /h		11.25		13.84
1200 rpm at max. pressure	gpm	48.71	39.61	58.51	48.75
Technical specifications					
Media ²⁾ temperature	°C	2 - 50	2 - 50	2 - 50	2 - 50
	°F	35.6 - 122	35.6 - 122	35.6 - 122	35.6 - 122
Ambient temperature	°C	0 - 50	0 - 50	0 - 50	0 - 50
	°F	32 - 122	32 - 122	32 - 122	32 - 122
Weight (dry)	kg	78	78	78	78
	lb	172	172	172	172
Sound pressure level ⁴⁾	dB(A)	85	85	85	85
Footprint with IEC motor ⁵⁾	m ²	0.48	0.48	0.54	0.54
	foot ²	5.17	5.17	5.81	5.81
Typical motor size					
Max. speed at max. pressure	kW		30.0		37.0
1200 rpm at max. pressure	HP	40.0		50.0	
Torque at max. outlet pressure	Nm	229	166	274	204
	lbf-ft	169	123	202	150

¹⁾ For lower and higher pressure, please contact Danfoss.

²⁾ Dependent on the NaCl concentration - see chapter 8.

³⁾ Category 2, Zone 1 or Category 3, Zone 2.

⁴⁾ A-weighted sound pressure level at 1 m from the pump unit surfaces (reference box) acc. to EN ISO 20361 section 6.2. The noise measurements are performed acc. to EN ISO 3744:2010 on a motor-pump unit at max. pressure and speed.

⁵⁾ Max. area covered with recommended motor configuration (excl. of space to service pump)

4.5 APP 16-22

Pump size		APP 16/1200	APP 16/1500	APP 17/1200	APP 17/1500	APP 19/1200	APP 19/1500	APP 22/1200	APP 22/1500
Code number APP		180B3254	180B3250	180B3255	180B3251	180B3256	180B3252	180B3257	180B3253
Code number APP ATEX ³⁾		180B3264	180B3260	180B3265	180B3261	180B3266	180B3262	180B3267	180B3263
Geometric displacement	cm ³ /rev.	234.6	188.3	253.3	197.5	272.3	219.7	310.6	253.3
	in ³ /rev.	14.32	11.49	15.46	12.05	16.62	13.41	18.95	15.46
Pressure									
Max. outlet ¹⁾ pressure continuous	barg	80	70	80	70	80	70	80	70
	psig	1160	1015	1160	1015	1160	1015	1160	1015
Min. outlet ¹⁾ pressure	barg	10	10	10	10	10	10	10	10
	psig	145	145	145	145	145	145	145	145
Inlet pressure continuous	barg	2 - 5	2 - 5	2 - 5	2 - 5	2 - 5	2 - 5	2 - 5	2 - 5
	psig	29 - 72.5	29 - 72.5	29 - 72.5	29 - 72.5	29 - 72.5	29 - 72.5	29 - 72.5	29 - 72.5
Max. inlet pressure peak	barg	10	10	10	10	10	10	10	10
	psig	145	145	145	145	145	145	145	145
Speed									
Min. speed continuous	rpm	700	700	700	700	700	700	700	700
Max. speed continuous	rpm	1200	1500	1200	1500	1200	1500	1200	1500
Typical flow - Flow curves available in item 5									
1000 rpm at max. pressure	m ³ /h	13.38	10.67	14.57	11.25	15.71	12.55	18.06	14.61
1500 rpm at max. pressure	m ³ /h		16.01		16.88		18.82		21.92
1200 rpm at max. pressure	gpm	70.70	56.40	76.98	59.44	82.98	66.30	95.43	77.21
Technical specifications									
Media ²⁾ temperature	°C	2 - 50	2 - 50	2 - 50	2 - 50	2 - 50	2 - 50	2 - 50	2 - 50
	°F	35.6 - 122	35.6 - 122	35.6 - 122	35.6 - 122	35.6 - 122	35.6 - 122	35.6 - 122	35.6 - 122
Ambient temperature	°C	0 - 50	0 - 50	0 - 50	0 - 50	0 - 50	0 - 50	0 - 50	0 - 50
	°F	32 - 122	32 - 122	32 - 122	32 - 122	32 - 122	32 - 122	32 - 122	32 - 122
Weight (dry)	kg	78	78	78	78	78	78	78	78
	lb	172	172	172	172	172	172	172	172
Sound pressure level ⁴⁾	dB(A)	84	84	84	84	84	84	84	84
Footprint with IEC motor ⁵⁾	m ²	0.54	0.58	0.59	0.59	0.76	0.76	0.80	0.80
	foot ²	5.81	6.26	6.35	6.35	8.18	8.18	8.61	8.61
Typical motor size									
Max. speed at max. pressure	kW		37.0		37.0		45.0		55.0
1200 rpm at max. pressure	HP	60.0		60.0		75.0		75.0	
Torque at max. outlet pressure	Nm	316	223	343	234	372	263	426	305
	lbf-ft	233	165	253	173	275	194	314	225

¹⁾ For lower and higher pressure, please contact Danfoss.

²⁾ Dependent on the NaCl concentration - see chapter 8.

³⁾ Category 2, Zone 1 or Category 3, Zone 2.

⁴⁾ A-weighted sound pressure level at 1 m from the pump unit surfaces (reference box) acc. to EN ISO 20361 section 6.2. The noise measurements are performed acc. to EN ISO 3744:2010 on a motor-pump unit at max. pressure and speed.

⁵⁾ Max. area covered with recommended motor configuration (excl. of space to service pump)

Data sheet | APP 0.6-43 / APP (W) 5.1-10.2 pumps
4.6 APP 21-30

Pump size		APP 21/1200	APP 21/1500	APP 24/1200	APP 24/1500	APP 26/1200	APP 26/1500	APP 30/1200	APP 30/1500
Code number APP		180B3051	180B3052	180B3054	180B3055	180B3056	180B3057	180B3060	180B3062
Code number APP ATEX³⁾		180B3151	On request	180B3154	180B3155	On request	On request	On request	On request
Geometric displacement	cm ³ /rev.	308.5	256	362	282	389	308.5	444	362
	in ³ /rev.	18.83	15.62	22.09	17.21	23.74	18.83	27.09	22.09
Pressure									
Max. outlet ¹⁾ pressure continuous	barg	80	80	80	80	80	80	80	80
	psig	1160	1160	1160	1160	1160	1160	1160	1160
Min. outlet ¹⁾ pressure	barg	10	10	10	10	10	10	10	10
	psig	145	145	145	145	145	145	145	145
Inlet pressure continuous	barg	2 - 5	2 - 5	2 - 5	2 - 5	2 - 5	2 - 5	2 - 5	2 - 5
	psig	29 - 72.5	29 - 72.5	29 - 72.5	29 - 72.5	29 - 72.5	29 - 72.5	29 - 72.5	29 - 72.5
Max. inlet pressure peak	barg	10	10	10	10	10	10	10	10
	psig	145	145	145	145	145	145	145	145
Speed									
Min. speed continuous	rpm	700	700	700	700	700	700	700	700
Max. speed continuous	rpm	1200	1500	1200	1500	1200	1500	1200	1500
Typical flow - Flow curves available in item 5									
1000 rpm at max. pressure	m ³ /h	17.80	14.80	21.02	16.36	22.47	17.86	26.05	21.12
1500 rpm at max. pressure	m ³ /h		22.20		24.54		26.79		31.69
1200 rpm at max. pressure	gpm	94.07	78.18	111.03	86.43	118.71	94.37	137.64	111.60
Technical specifications									
Media ²⁾ temperature	°C	2 - 50	2 - 50	2 - 50	2 - 50	2 - 50	2 - 50	2 - 50	2 - 50
	°F	35.6 - 122	35.6 - 122	35.6 - 122	35.6 - 122	35.6 - 122	35.6 - 122	35.6 - 122	35.6 - 122
Ambient temperature	°C	0 - 50	0 - 50	0 - 50	0 - 50	0 - 50	0 - 50	0 - 50	0 - 50
	°F	32 - 122	32 - 122	32 - 122	32 - 122	32 - 122	32 - 122	32 - 122	32 - 122
Weight (dry)	kg	105	105	105	105	105	105	105	105
	lb	231	231	231	231	231	231	231	231
Sound pressure level ⁴⁾	dB(A)	85	85	85	85	85	85	85	85
Footprint with IEC motor ⁵⁾	m ²	0.76	0.76	0.80	0.80	0.83	0.83	0.83	0.83
	foot ²	8.18	8.18	8.61	8.61	8.93	8.93	8.93	8.93
Typical motor size									
Max. speed at max. pressure	kW	55.0	75.0	55.0	75.0	75.0	75.0	90.0	90.0
1200 rpm at max. pressure	HP	75.0		100.0		100.0		125.0	
Torque at max. outlet pressure	Nm	418	355	490	388	527	426	608	498.68
	lbf-ft	308	262	361	286	389	314	449	367.81

¹⁾ For lower and higher pressure, please contact Danfoss.

²⁾ Dependent on the NaCl concentration - see chapter 8.

³⁾ Category 2, Zone 1 or Category 3, Zone 2.

⁴⁾ A-weighted sound pressure level at 1 m from the pump unit surfaces (reference box) acc. to EN ISO 20361 section 6.2. The noise measurements are performed acc. to EN ISO 3744:2010 on a motor-pump unit at max. pressure and speed.

⁵⁾ Max. area covered with recommended motor configuration (excl. of space to service pump)

4.7 APP 38-43

Pump size		APP 38/1500	APP 43/1700
Code number APP		180B3071	180B3072
Code number APP ATEX ³⁾		On request	Not available
Geometric displacement	cm ³ /rev.	444	444
	in ³ /rev.	27.09	27.09
Pressure			
Max. outlet ¹⁾ pressure continuous	barg	80	70
	psig	1160	1015
Min. outlet ¹⁾ pressure	barg	10	10
	psig	145	145
Inlet pressure continuous	barg	2 - 5	2.5 - 5
	psig	29 - 72.5	36.5 - 72.5
Max. inlet pressure. peak	barg	10	10
	psig	145	145
Speed			
Min. speed continuous	rpm	700	700
Max. speed continuous	rpm	1500	1700
Typical flow - Flow curves available in item 5			
1000 rpm at max. pressure	m ³ /h	26.20	26.29
1500 rpm at max. pressure	m ³ /h	39.30	39.44
1200 rpm at max. pressure	gpm	138.41	138.91
Technical specifications			
Media ²⁾ temperature	°C	2 - 50	2 - 50
	°F	35.6 - 122	35.6 - 122
Ambient temperature	°C	0-50	0-50
	°F	32 - 122	32 - 122
Weight (dry)	kg	105	105
	lb	231	231
Sound pressure level ⁴⁾	dB(A)	85	85.3
Footprint with IEC motor ⁵⁾	m ²	0.83	1.10
	foot ²	8.93	11.84
Typical motor size			
Max. speed at max. pressure	kW	110.0	100.0
Torque at max. outlet pressure	Nm	617	546
	lbf-ft	455	402

¹⁾ For lower and higher pressure, please contact Danfoss.

²⁾ Dependent on the NaCl concentration - see chapter 8.

³⁾ Category 2, Zone 1 or Category 3, Zone 2.

⁴⁾ A-weighted sound pressure level at 1 m from the pump unit surfaces (reference box) acc. to EN ISO 20361 section 6.2. The noise measurements are performed acc. to EN ISO 3744:2010 on a motor-pump unit at max. pressure and speed.

⁵⁾ Max. area covered with recommended motor configuration (excl. of space to service pump)

5. Flow at different rpm

If the flow required and the rotation speed (rpm) of the pump is known, it is easy to select the pump fitting the application best by using the diagrams below.

Furthermore, these diagrams shows that the flow can be changed by changing the rotation speed of the pump. The flow/rpm ratio is constant, and the "required" flow can be obtained by changing the rotation speed to a corresponding value. Thus, the required rpm can be determined as:

$$\text{Required rpm} = \frac{\text{Required flow} \times \text{Rated rpm}}{\text{Rated flow}}$$

5.1 APP 0.6-1.0 flow curves measured at 80 barg (1160 psig)

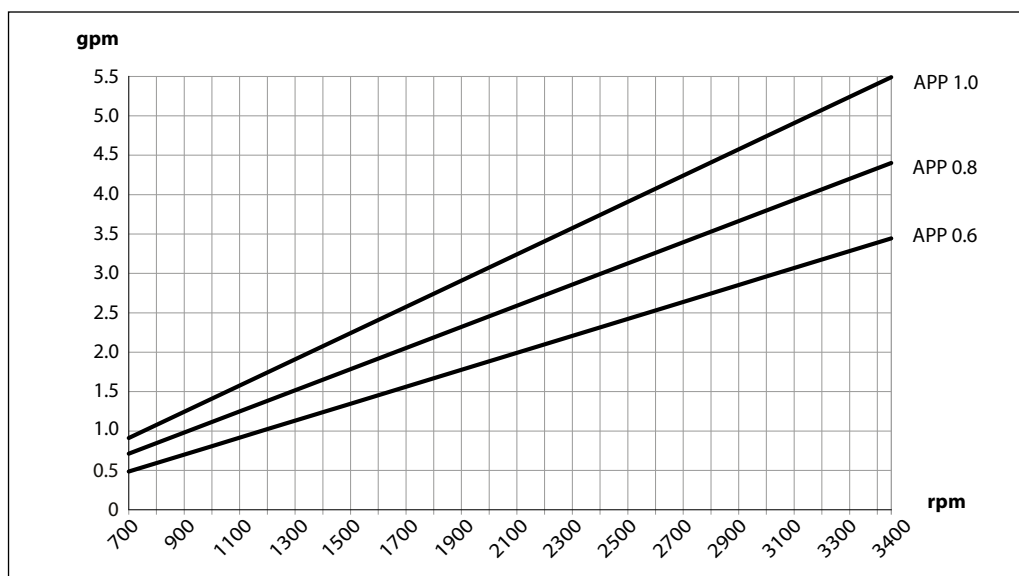
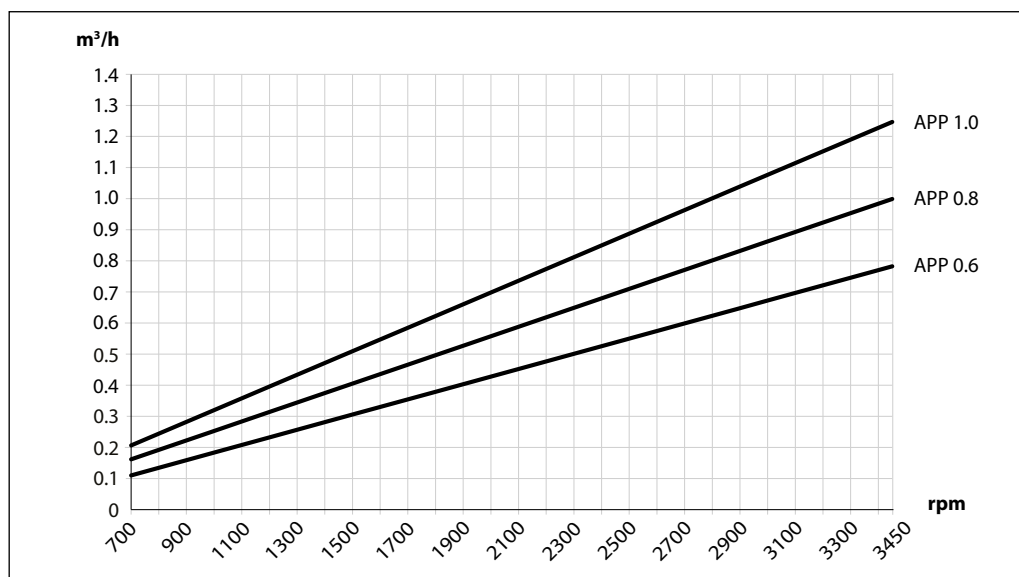

5.2 APP 1.5-3.5 flow curves at 80 barg (1160 psig)

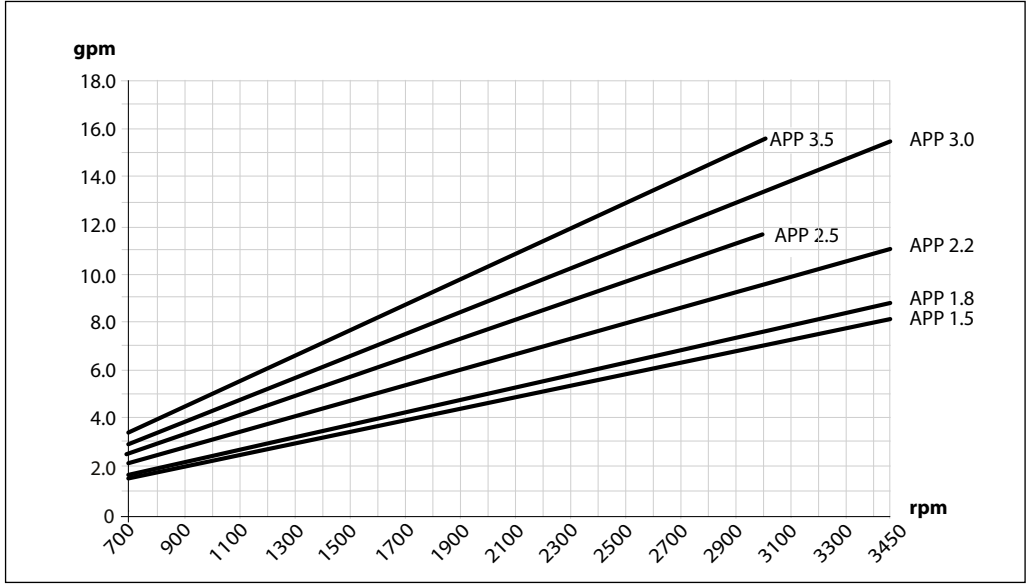
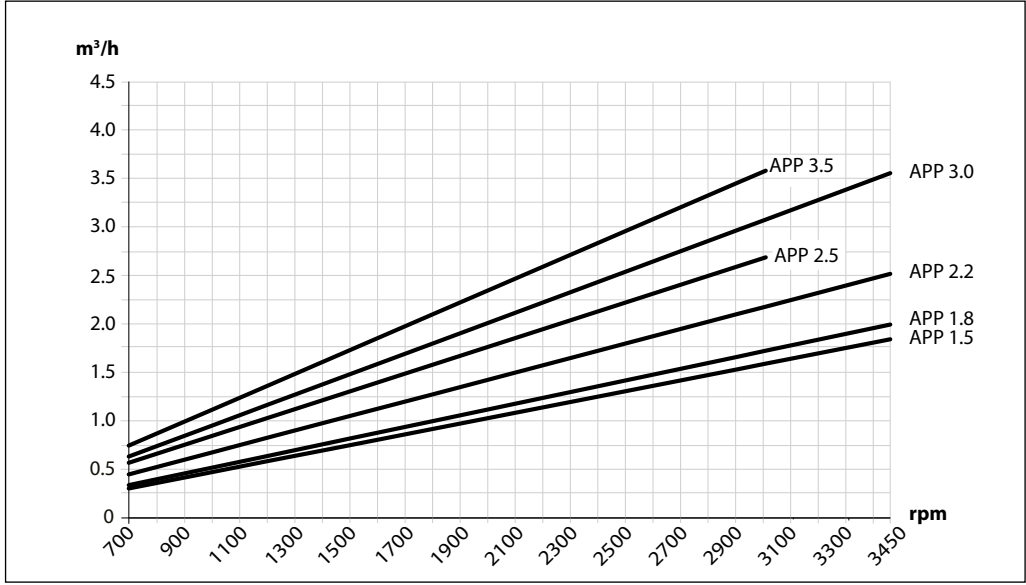

5.3 APP (W) 5.1-10.2 flow curves at 80 barg (1160 psig)

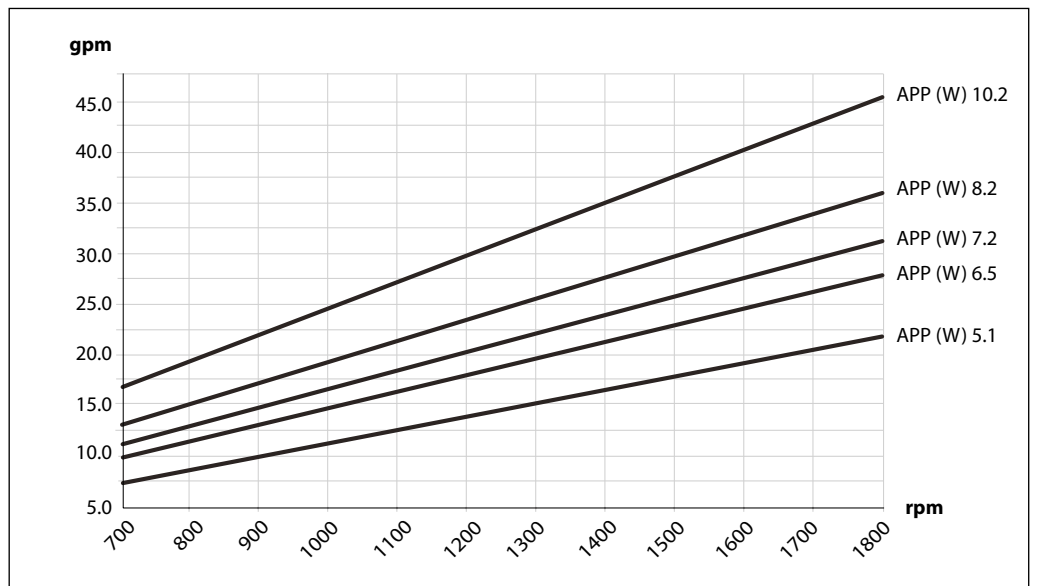
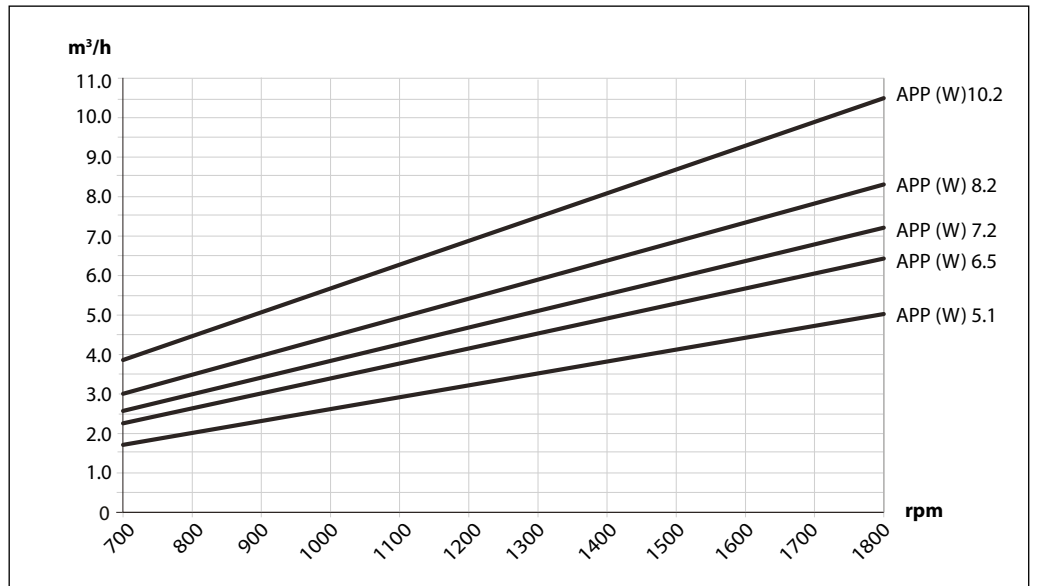

5.4 APP 11-13 flow curves at 60 barg (870 psig)

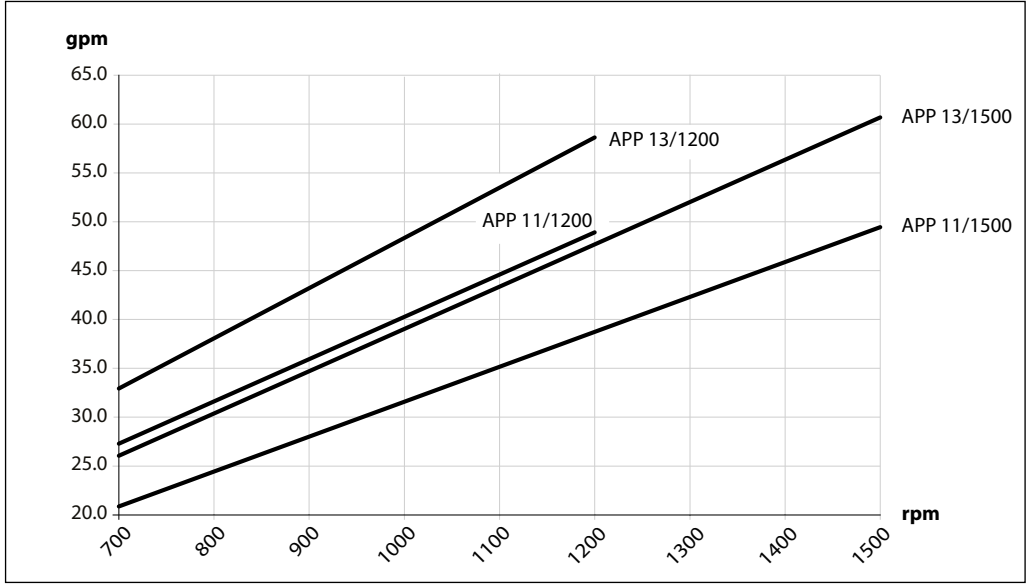
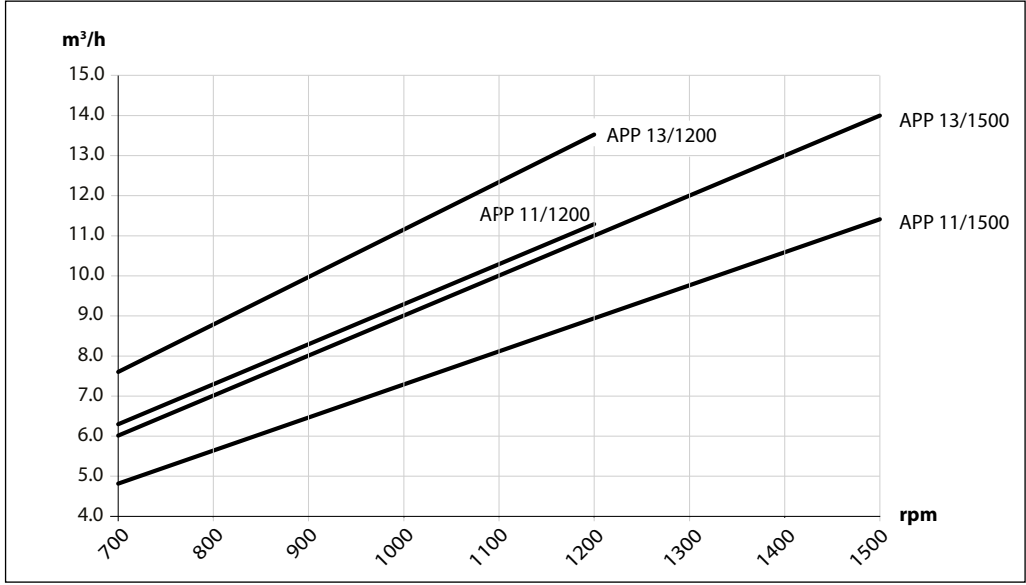

5.5 APP 16-22 flow curves at 60 barg (870 psig)

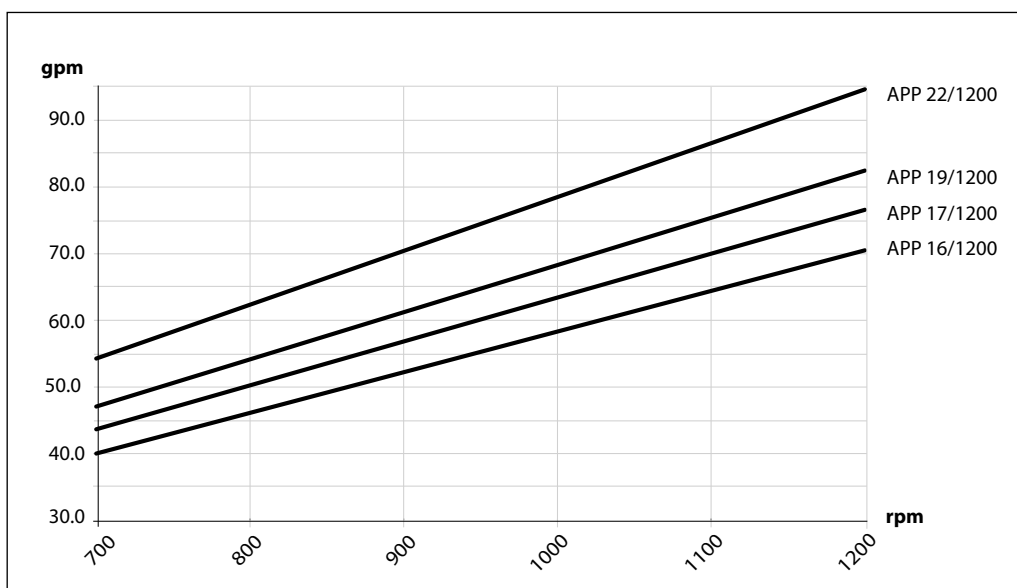
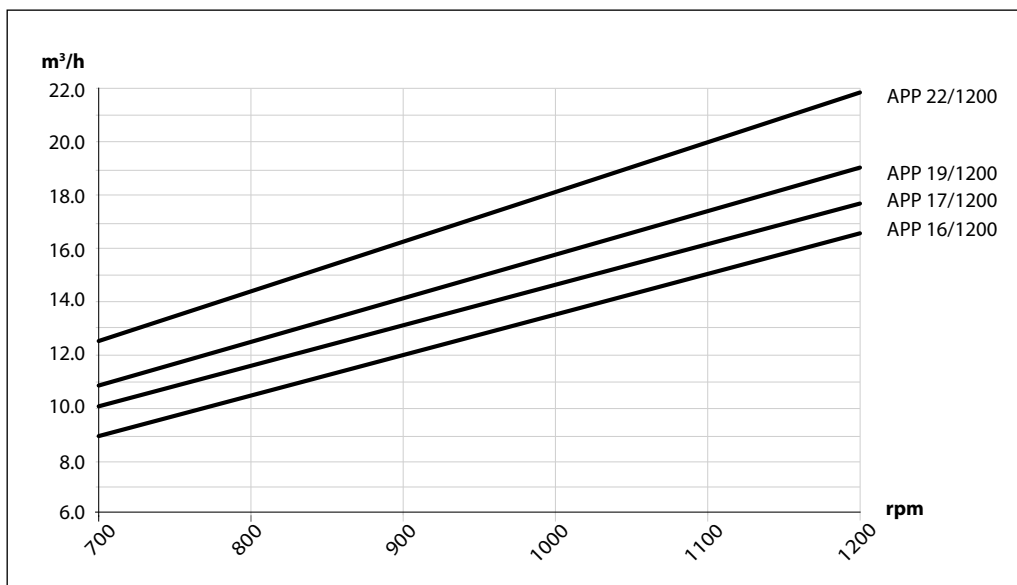

5.6 APP 16-22 flow curves at 60 barg (870 psig)

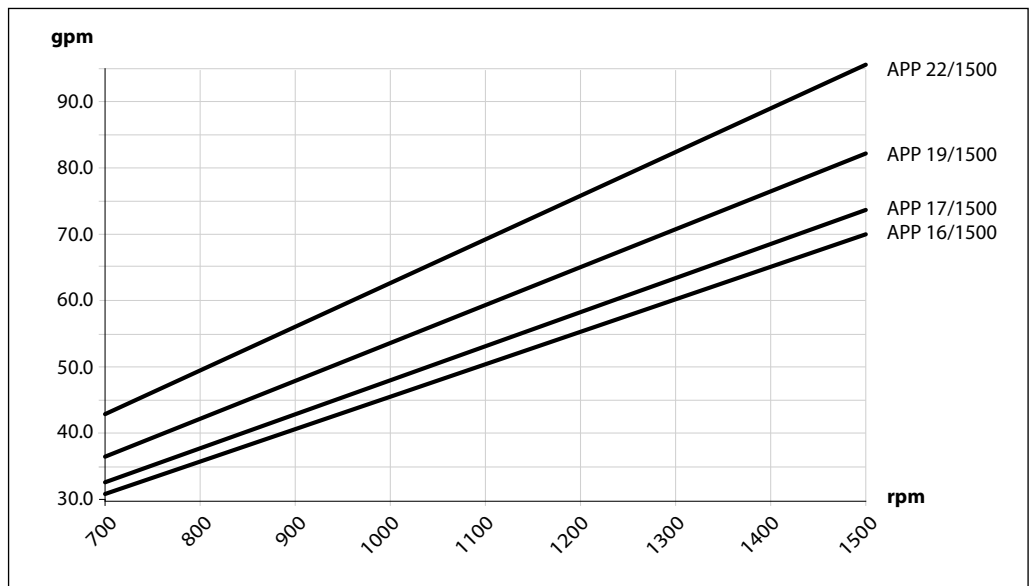
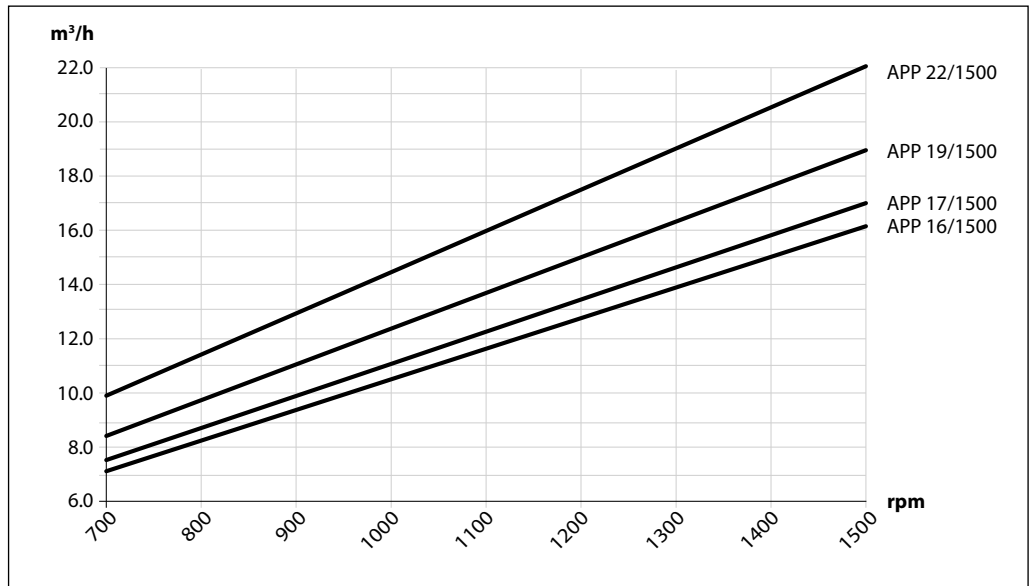

5.7 APP 21-30 flow curves at 60 barg (870 psig)

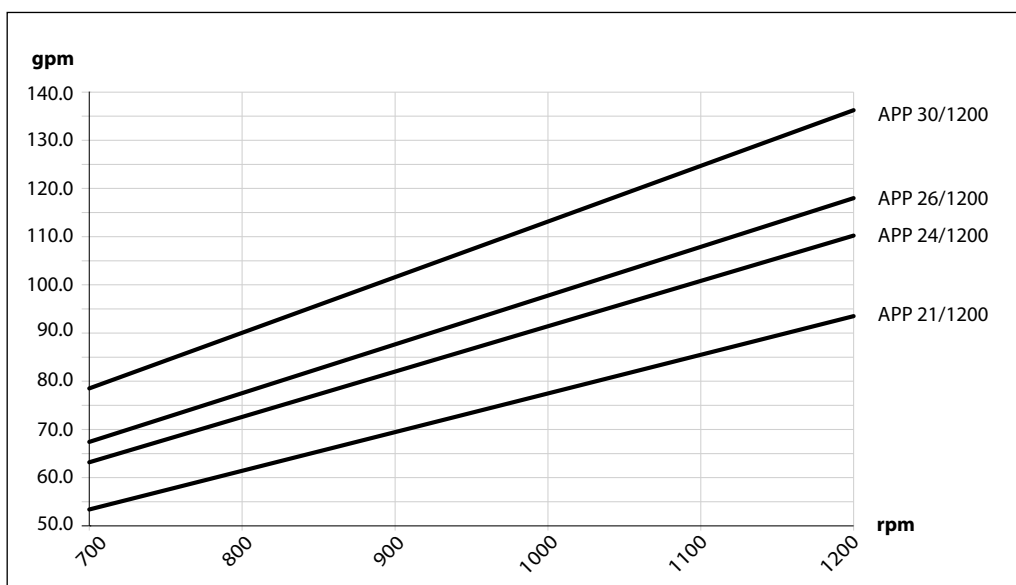
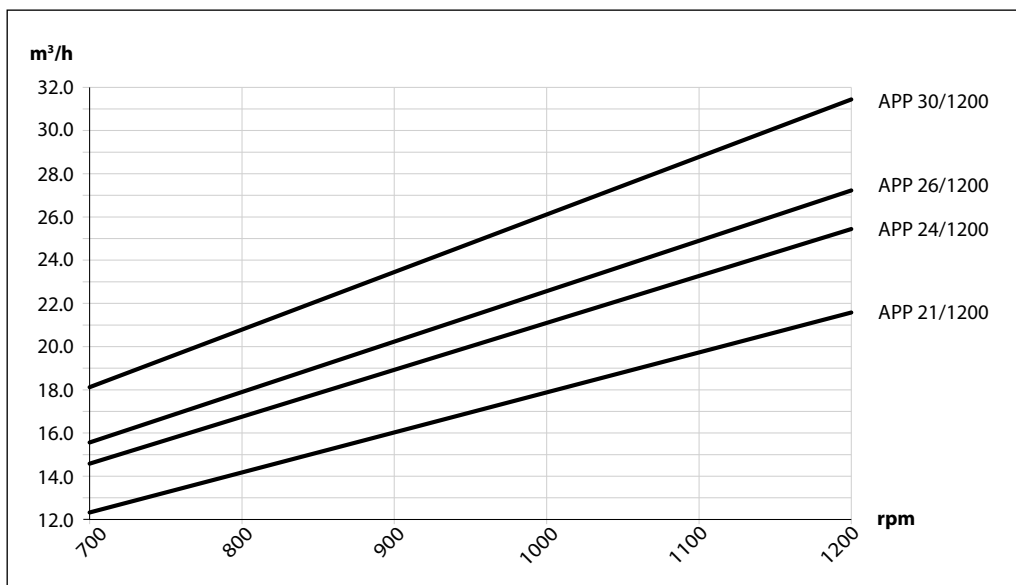

5.8 APP 21-38 flow curves at 60 barg (870 psig)

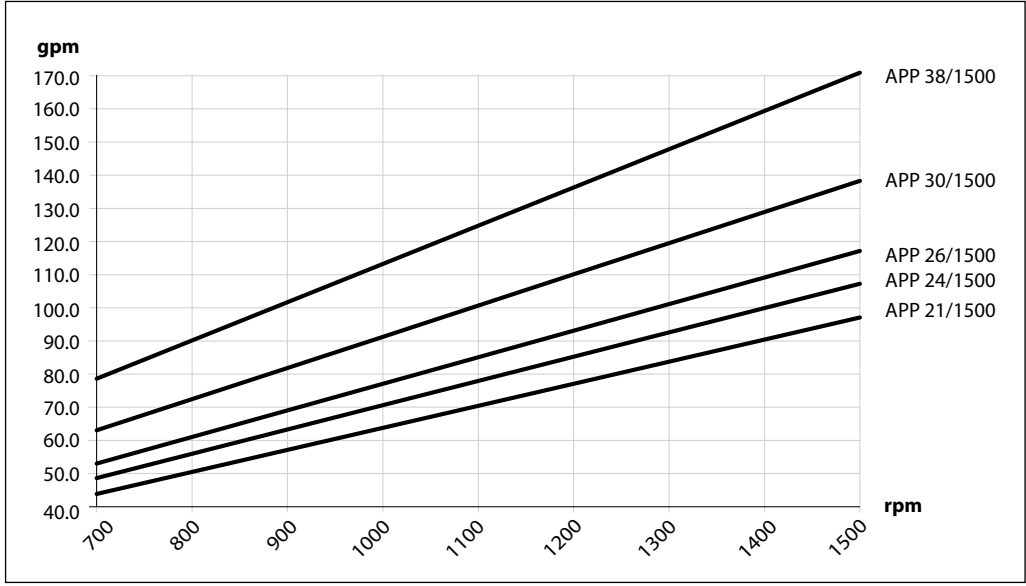
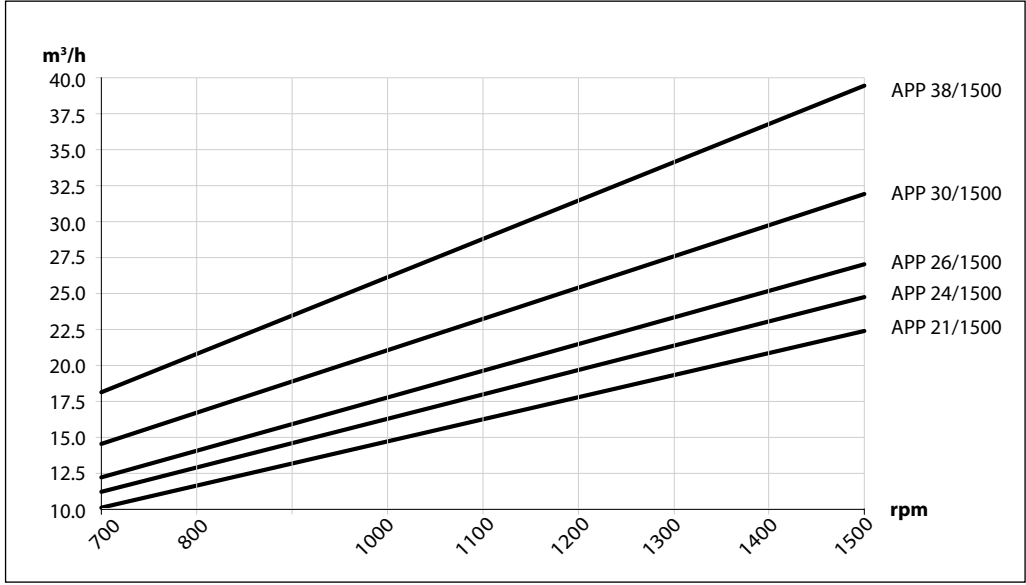

5.9 APP 43 flow curves 60 barg (870 psig)

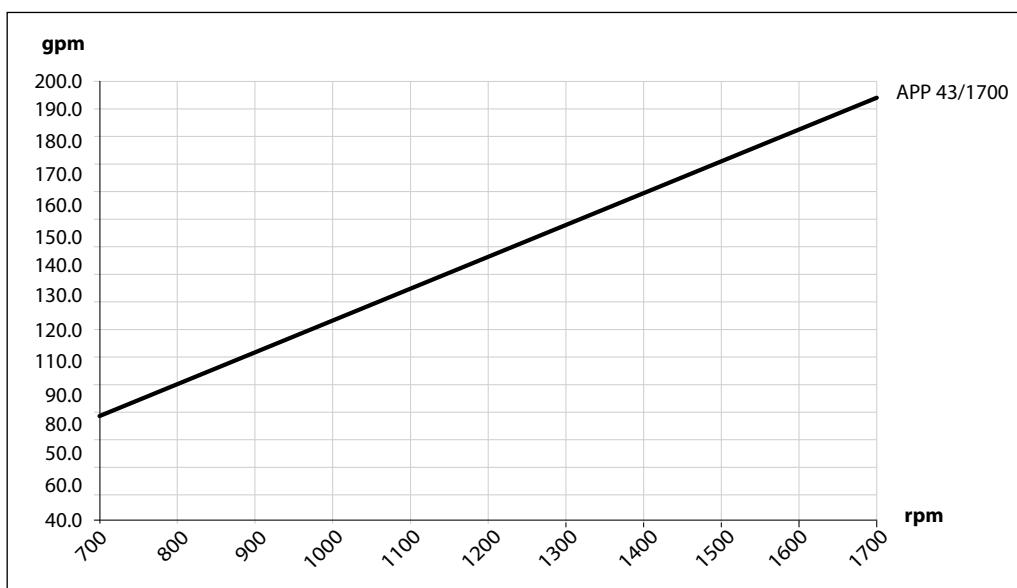
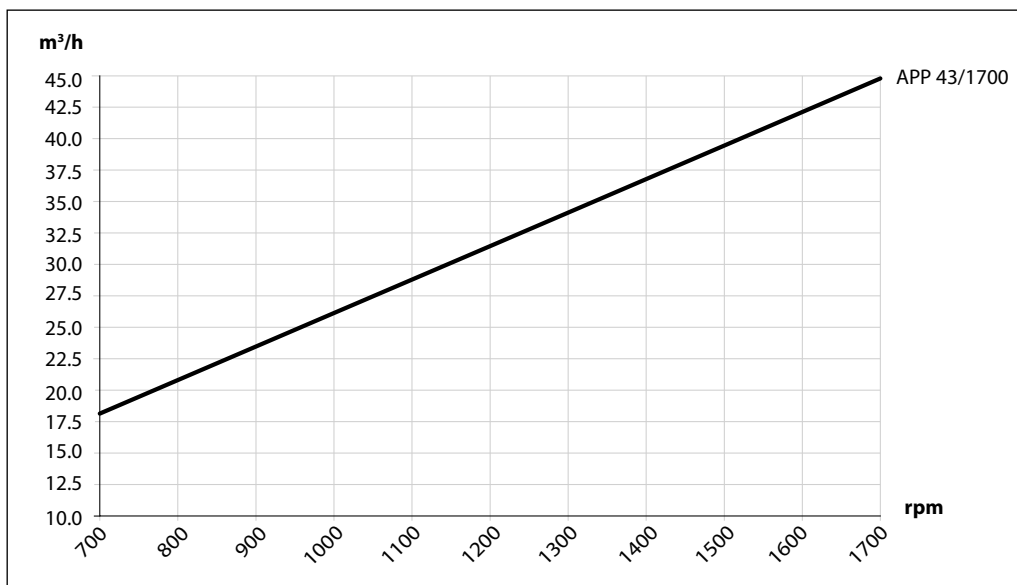

6 Flushing valve curves All pumps except APP (W) 5.1 - 10.2 are supplied with an integrated flushing valve that allows the fluid to flow from inlet to the outlet, when the pump is not running.

6.1 APP 0.6-1.0 integrated flushing valve

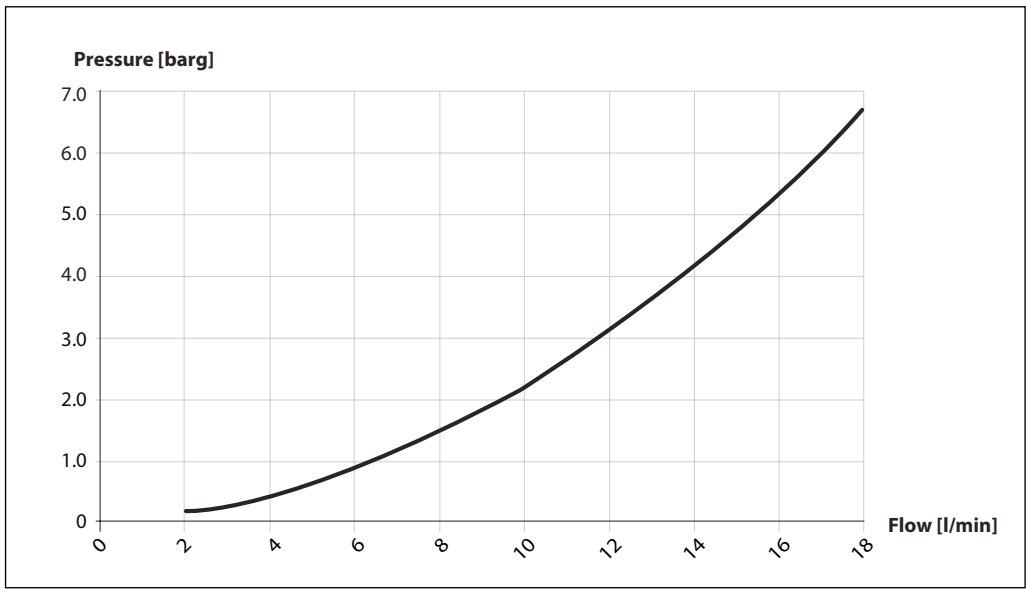

6.2 APP 1.5-3.5 integrated flushing valve

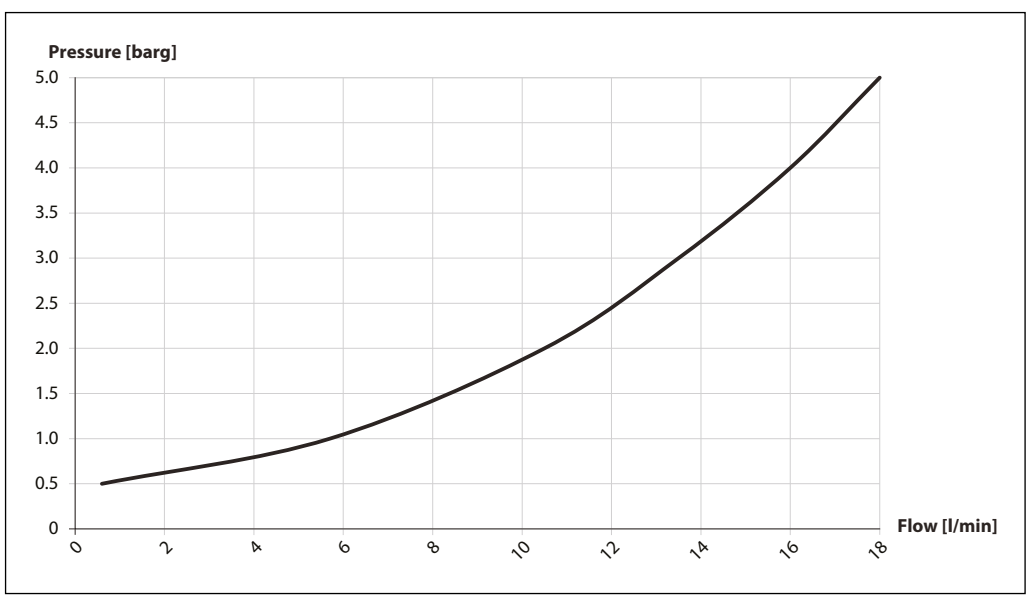

6.3 APP 5.1-10.2 Flushing valve not available

6.4 APP 11-13 integrated flushing valve

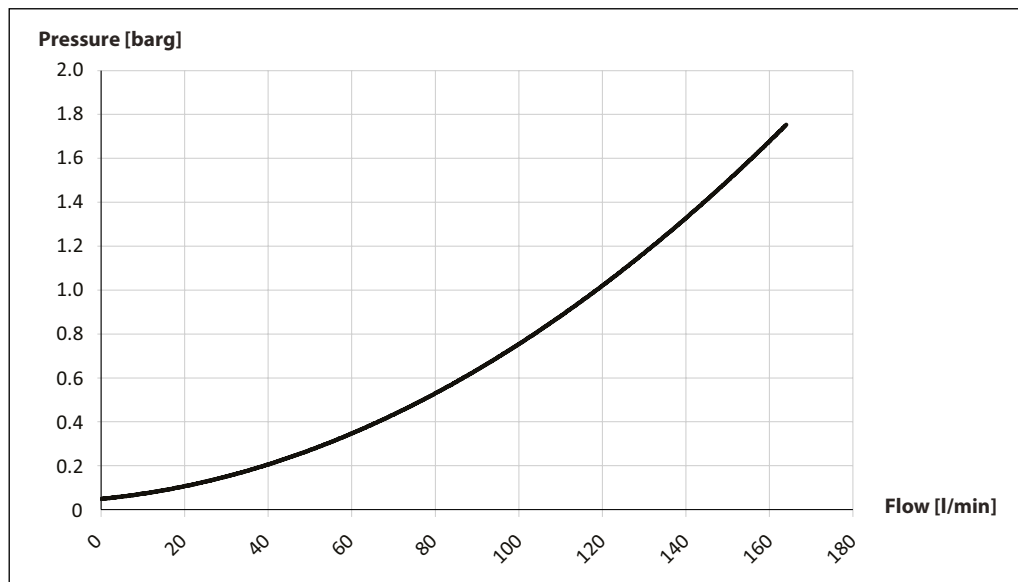

6.5 APP 16-22 integrated flushing valve

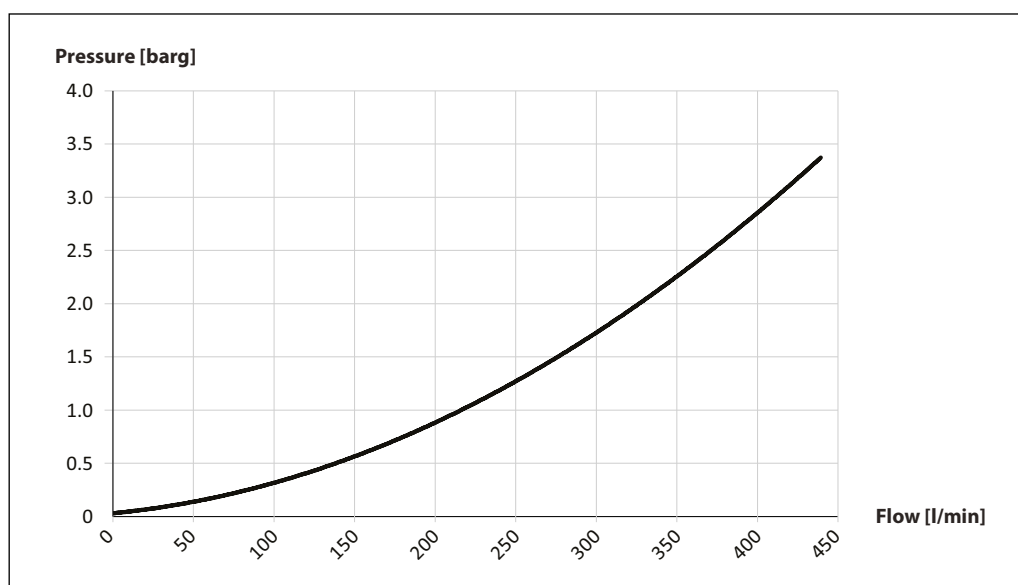

6.6 APP 21-43 integrated flushing valve

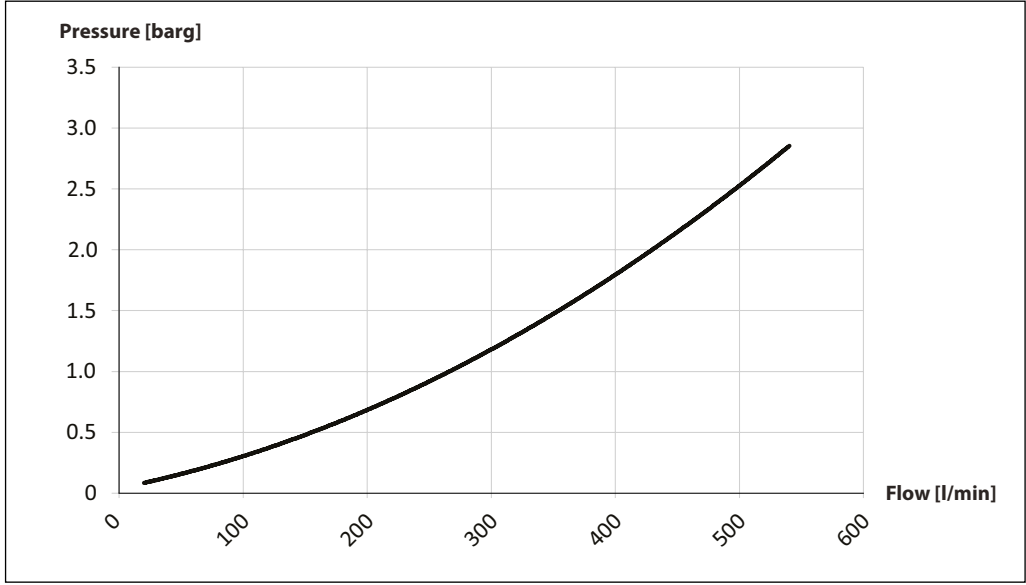

7. Motor requirements

The power requirements can be determined using one of the following guiding equations:

$$\text{Required power} = \frac{\text{l/min} \times \text{barg}}{\text{Calc. factor}} \text{ [kW]} \text{ or } \frac{16.7 \times \text{m}^3/\text{h} \times \text{barg}}{\text{Calc. factor}} \text{ [kW]} \text{ or } \frac{0.26 \times \text{gpm} \times \text{psig}}{\text{Calc. factor}}$$

1 hp	=	0.75 kW
1 gpm	=	3.79 l/min
1 m ³ /h	=	4.40 gpm
1 kW	=	1.34 hp
1 l/min	=	0.26 gpm
1 gpm	=	0.23 m ³ /h

7.1 Calculation factor for APP 0.6-1.0

Name	rpm	Calculation factor
APP 0.6	3450	496
APP 0.8	3450	509
APP 1.0	3450	512

7.2 Calculation factor for APP 1.5-3.5

Name	rpm	Calculation factor
APP 1.5	3450	519
APP 1.8	3450	524
APP 2.2	3450	532
APP 2.5	3000	535
APP 3.0	3450	532
APP 3.5	3000	530

7.3 Calculation factor for APP (W) 5.1-10.2

Name	rpm	Calculation factor
APP (W) 5.1	1800	506
APP (W) 6.5	1800	514
APP (W) 7.2	1800	518
APP (W) 8.2	1800	523
APP (W) 10.2	1800	528

7.4 Calculation factor for APP 11-13

Name	rpm	Calculation factor
APP 11	1200	513
APP 11	1500	502
APP 13	1200	516
APP 13	1500	505

7.5 Calculation factor for APP 16-22

Name	rpm	Calculation factor
APP 16	1200	540
APP 16	1500	533
APP 17	1200	541
APP 17	1500	536
APP 19	1200	537
APP 19	1500	531
APP 22	1200	540
APP 22	1500	535

7.6 Calculation factor for APP 21-43

Name	rpm	Calculation factor
APP 21	1200	543
APP 21	1500	531
APP 24	1200	547
APP 24	1500	537
APP 26	1200	543
APP 26	1500	534
APP 30	1200	545
APP 30	1500	540
APP 38	1500	541
APP 43	1700	537

8. Temperature and corrosion

8.1 Temperature

Fluid temperature: Min. +2°C to max. +50°C (Min. +35.6°F to max. +122°F)
Ambient temperature: Min. +2°C to max. +50°C (Min. +35.6°F to max. +122°F)

In case of lower operating temperatures, please contact Danfoss High Pressure Pumps.operation

stop in order to minimize the risk of crevice corrosion.

The chart below illustrates the corrosive resistance of different types of stainless steel related to NaCl concentration and temperature. The APP water pump is made of Duplex and Super Duplex.

If the water pump is operated above the Duplex line, always flush water pump with fresh water at operation stop in order to minimize the risk of crevice corrosion.

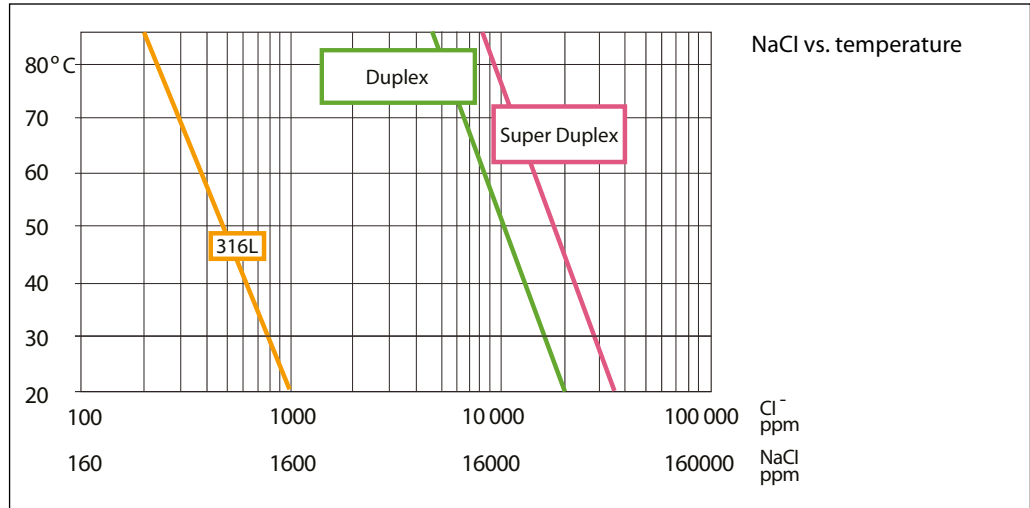

9. Installation

See example below on how to mount the pump and connect it to an electric motor or combustion engine (special coupling).

If alternative mounting is required, please contact your Danfoss sales representative for further information.

Note: Do not add any axial or radial loads to the pump shaft.

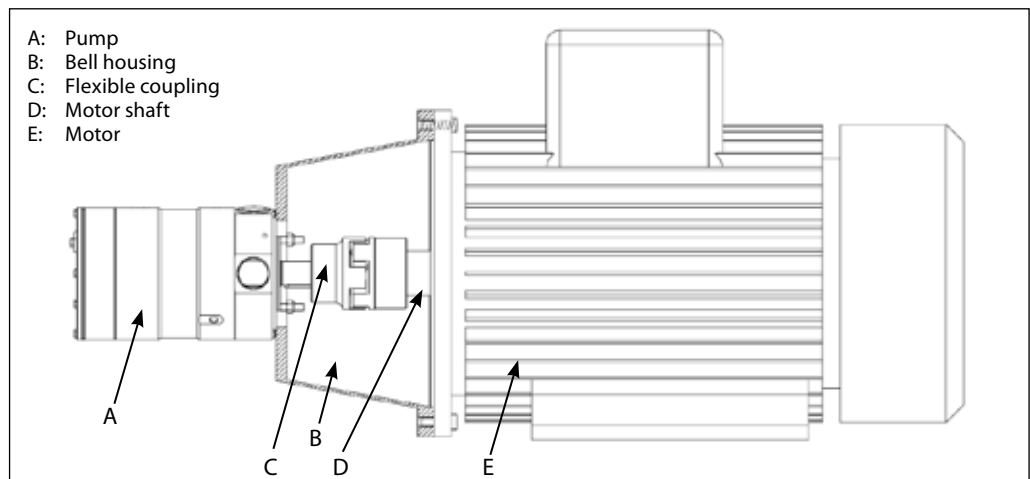

9.1 Filtration

Proper filtration is crucial for the performance, maintenance and warranty of your pump.

Protect your pump, and the application in which it is installed, and by always ensuring that all filtration specifications are met, and by always changing filter cartridges according to schedule.

Since water has very low viscosity, Danfoss APP pumps have been designed with very narrow clearances in order to control internal leakage rates and improve component performance.

To minimize wear on the pump, it is therefore essential to filter inlet water properly.

The main filter must have a filtration efficiency of 99.98% at 10 µm. We strongly recommend that you always use precision depth filter cartridges rated 10µm abs. $\beta_{10} \geq 5000$.

Please note that we do not recommend bag filters or string-wound filter cartridges, which typically have only 50% filtration efficiency. This means that out of the 100,000 particles that enter such filters, 50,000 particles pass right through; compare this to precision depth filters that are 99.98% efficient, and only allow 20 of the same 100,000 particles to pass through.

For more information on the importance of proper filtration, including explanation of filtration principles, definitions and guidance on how to select the right filter for your pump, please consult our Filtration information and specifications (Danfoss document number 521B1009).

Noise

Since the pump unit is typically mounted on a frame or bell housing the overall noise level can only be determined for a complete system. To minimize vibrations and noise throughout the system, it is therefore very important to mount the pump unit correctly on a frame with anti-vibration-dampeners, and to use flexible hoses rather than metal pipes where possible.

The noise level is influenced by:

- **Pump speed:**
High rpm generates more fluid/structure borne pulsations/vibrations than low rpm, because of higher frequency.
- **Discharge pressure:**
High pressure generates more noise than low pressure.
- **Pump mounting:**
Rigid mounting generates more noise than flexible mounting, because of structure-borne vibrations. Be sure to use dampers when mounting.
- **Connections to pump:**
Pipes connected directly to the pump make more noise than flexible hoses, because of structure-borne vibrations.

- **Variable frequency drives (VFD):**
Motors regulated by VFDs can produce more noise if the VFD does not have the right settings.

9.2 RO system with direct supply:

- Inlet line:**
- a) Dimension the inlet line to obtain minimum pressure loss (large flow, minimum pipe length, minimum number of bends/connections, and fittings with low or no pressure losses). If relevant, please consult "Parallel coupled pumps and iSaves" (180R93549)

- Inlet filter:**
- b) Install an inlet filter (1) in front of the APP pump (2). Please consult section 9.1, "Filtration" for guidance on how to select the right filter. Thoroughly clean pipes and flush system prior to start-up.

- Low pressure relief valve:**
- c) Install a low pressure relief valve (9) in order to avoid system or pump damage in case the pump stops momentarily or is spinning backwards.

- Monitoring pressure switch:**
- d) Install a monitoring pressure switch (3) between the filter (1) and the pump inlet. Set the minimum inlet pressure according to specifications described in item 4 about technical data. If the inlet pressure is lower than the minimum pressure set, the monitoring pressure switch must prevent the pump from starting or from running.

- Hoses:**
- e) Use flexible hoses (4) to minimize vibrations and noise. Please consult the Danfoss Hoses and hose fittings data sheet (521B0909) for guidance.

- Inlet pressure:**
- f) In order to eliminate the risk of cavitation and other pump damage, pump inlet pressure must always be maintained according to specifications described in item 4 about technical data.

- Flushing valve:**
- g) For easy system filling and flushing, an integrated flushing valve (6) is in the APP pump (except APP (W) 5.1-10.2).

- Non-return valve:**
- h) A non-return valve (7) in outlet can be installed in order to avoid backspin of the pump. The volume of water in the membrane vessel works as an accumulator and will send flow backwards in case of the pump stops momentarily.

- i) **High pressure safety or relief valve:**
 As the Danfoss APP pump begins to create pressure and flow immediately after start-up and regardless of any counter pressure, a safety or pressure relief valve (8) should be installed after the non-return valve to prevent system damage and to avoid high pressure peaks.

Note: If a non-return valve is mounted in the inlet line, a low-pressure relief valve is also required between the non-return valve and pump as protection against high-pressure peaks.

Preferred design - see section 9.2

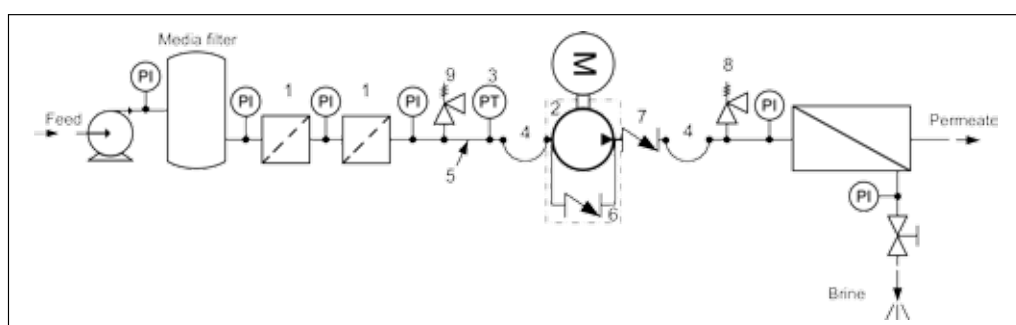

10. Dimensions and connections

10.1 APP 0.6-1.0

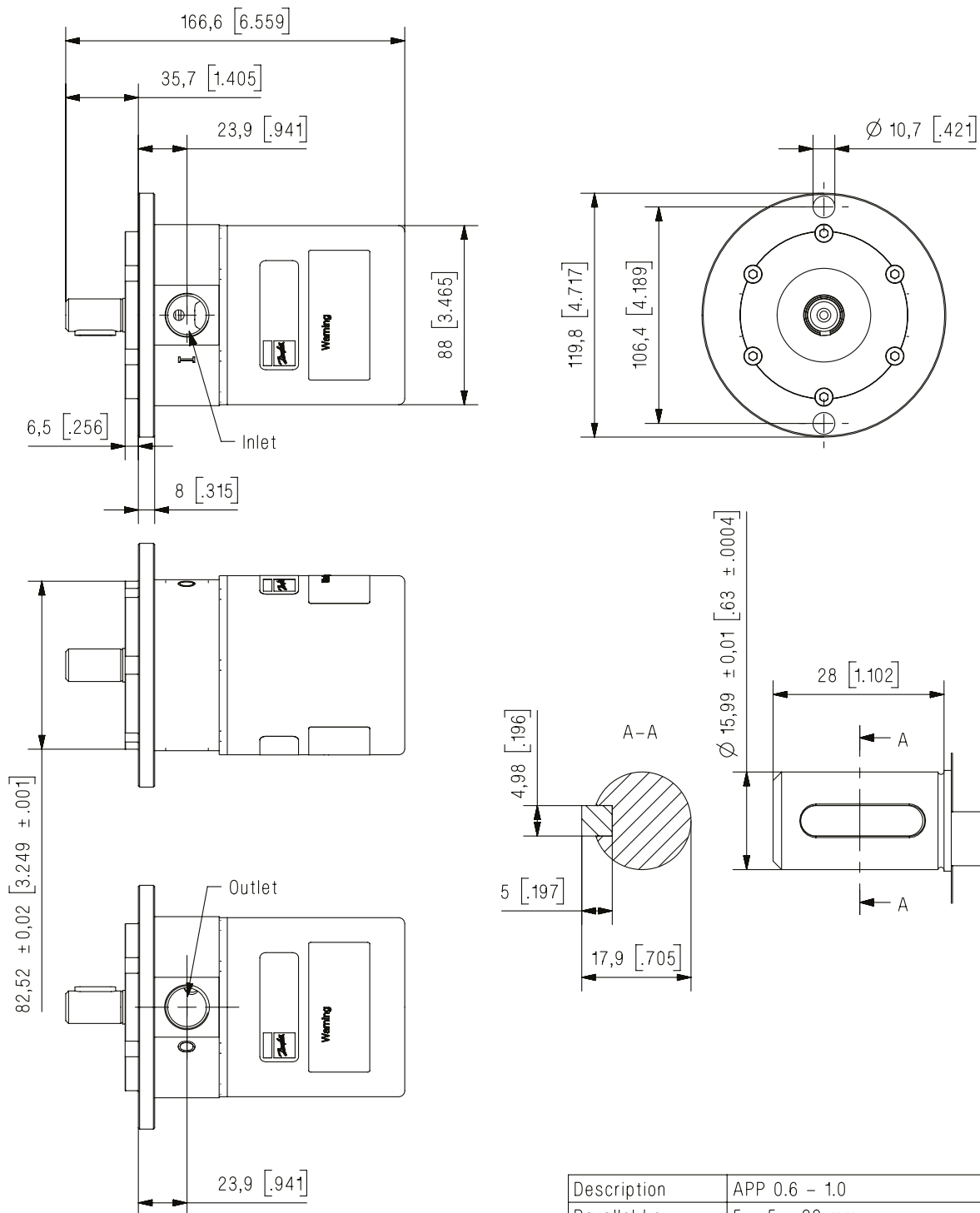

Dimensions without tolerances acc. To ISO 2768-1 designation C.

Description	APP 0.6 - 1.0
Parallel key Din 6885	5 x 5 x 20 mm 0.2 x 0.2 x 0.79 inch
Inlet	G 1/2"; depth 13 mm
Outlet	G 1/2"; depth 13 mm

10.2 APP 1.5-3.5

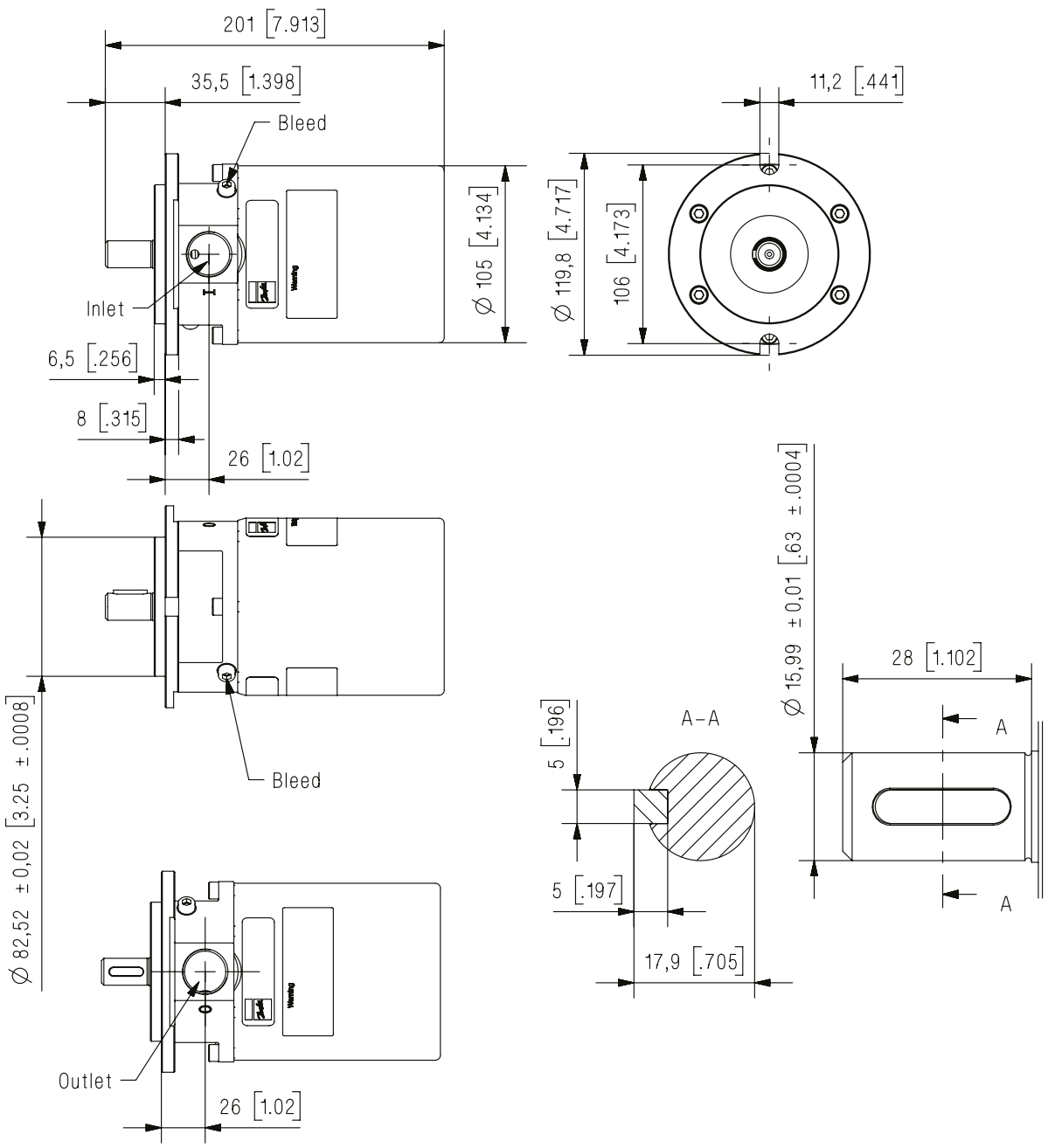

Dimensions without tolerances acc. To ISO 2768-1 designation C.

Description	APP 1.5-2.5 APP 3.0-3.5
Parallel key DIN 6885	5 x 5 x 20 mm 0.2 x 0.2 x 0.79 inch
Bleed	M6 hex key 5 mm
Inlet	G 3/4"; depth 16 mm
Outlet	G 3/4"; depth 16 mm

10.3 APP (W) 5.1-10.2

Accessories see page 33. For more details on the accessories, please contact the Danfoss High Pressure Pumps sales organisation.

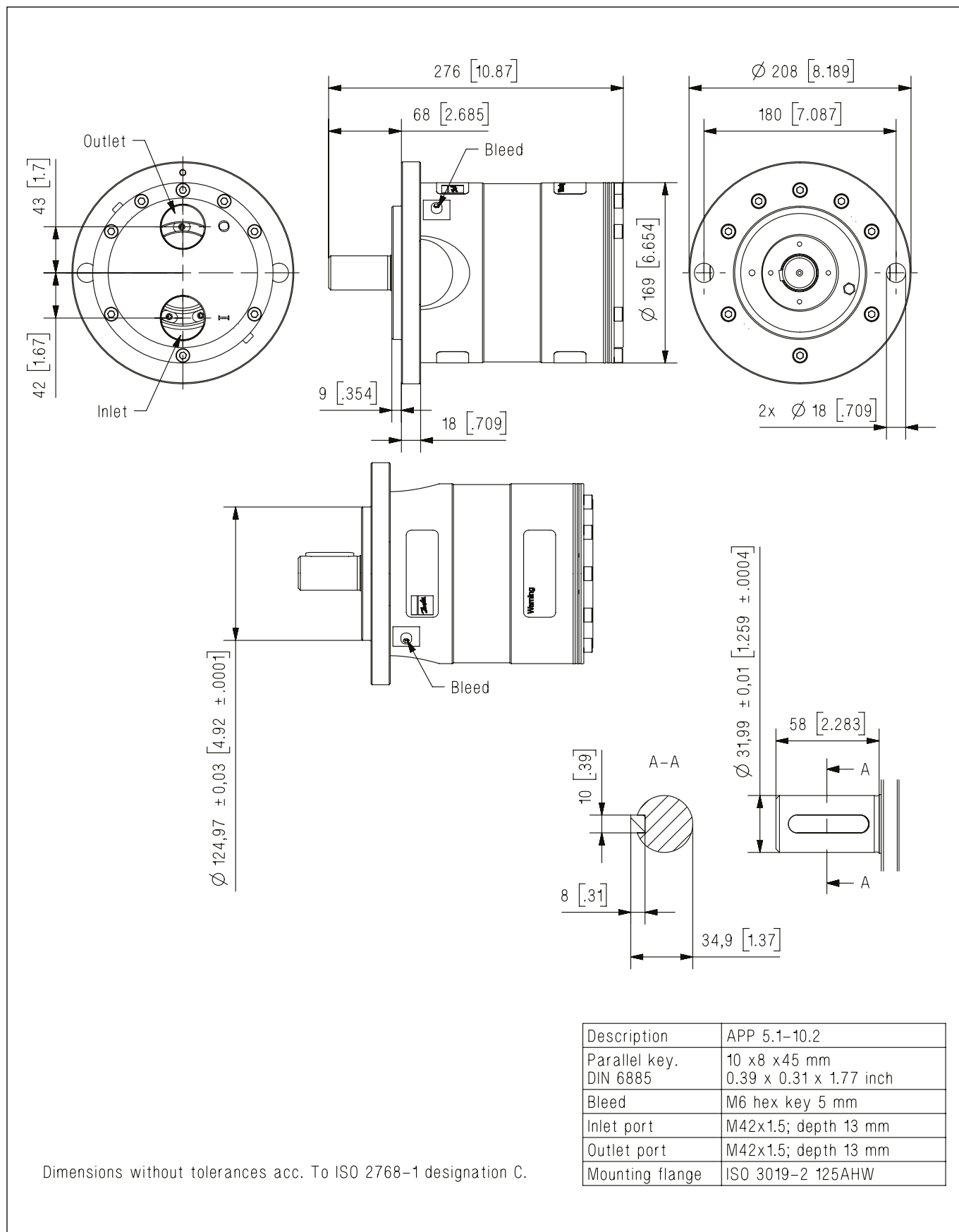

Description	APP 5.1-10.2
Parallel key.	10 x 8 x 45 mm
DIN 6885	0.39 x 0.31 x 1.77 inch
Bleed	M6 hex key 5 mm
Inlet port	M42x1.5; depth 13 mm
Outlet port	M42x1.5; depth 13 mm
Mounting flange	ISO 3019-2 125AHW

10.4 APP 11-13

Accessories see page 33. For more details on the accessories, please contact the Danfoss High Pressure Pumps sales organisation.

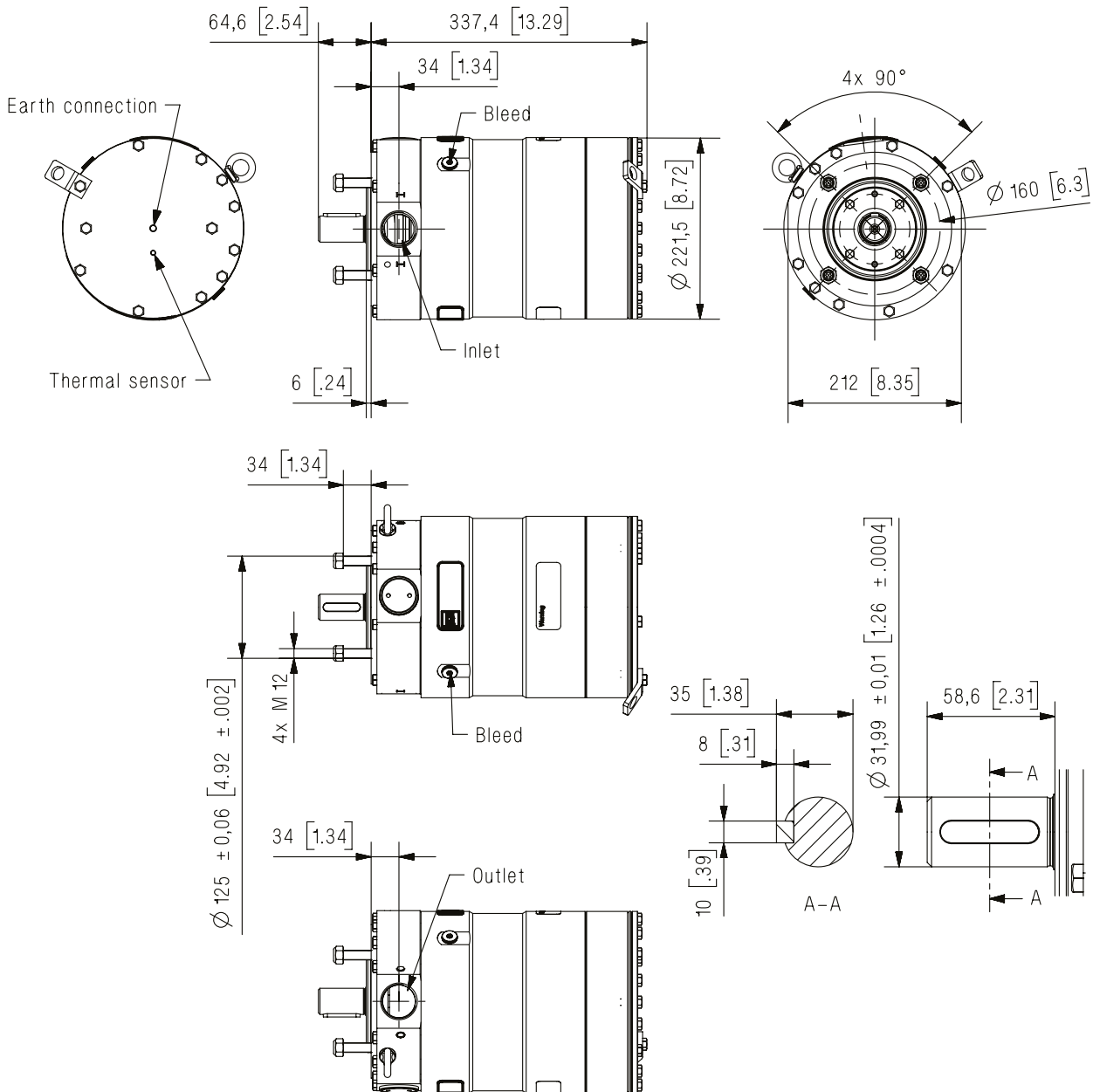

Description	APP 11-13
Parallel key, DIN 6885	10 x 8 x 45 mm 0.39 x 0.31 x 1.77 inch
Bleed	G 1/4", hex key 6 mm
Inlet port	M42x1.5; depth 17 mm
Outlet port	M42x1.5; depth 17 mm
Earth connection	M8, depth 8 mm
Thermal sensor	M6, depth 8 mm

Dimensions without tolerances acc. to ISO 2768-1 designation C.

10.5 APP 16-22

Accessories see page 33. For more details on the accessories, please contact the Danfoss High Pressure Pumps sales organisation.

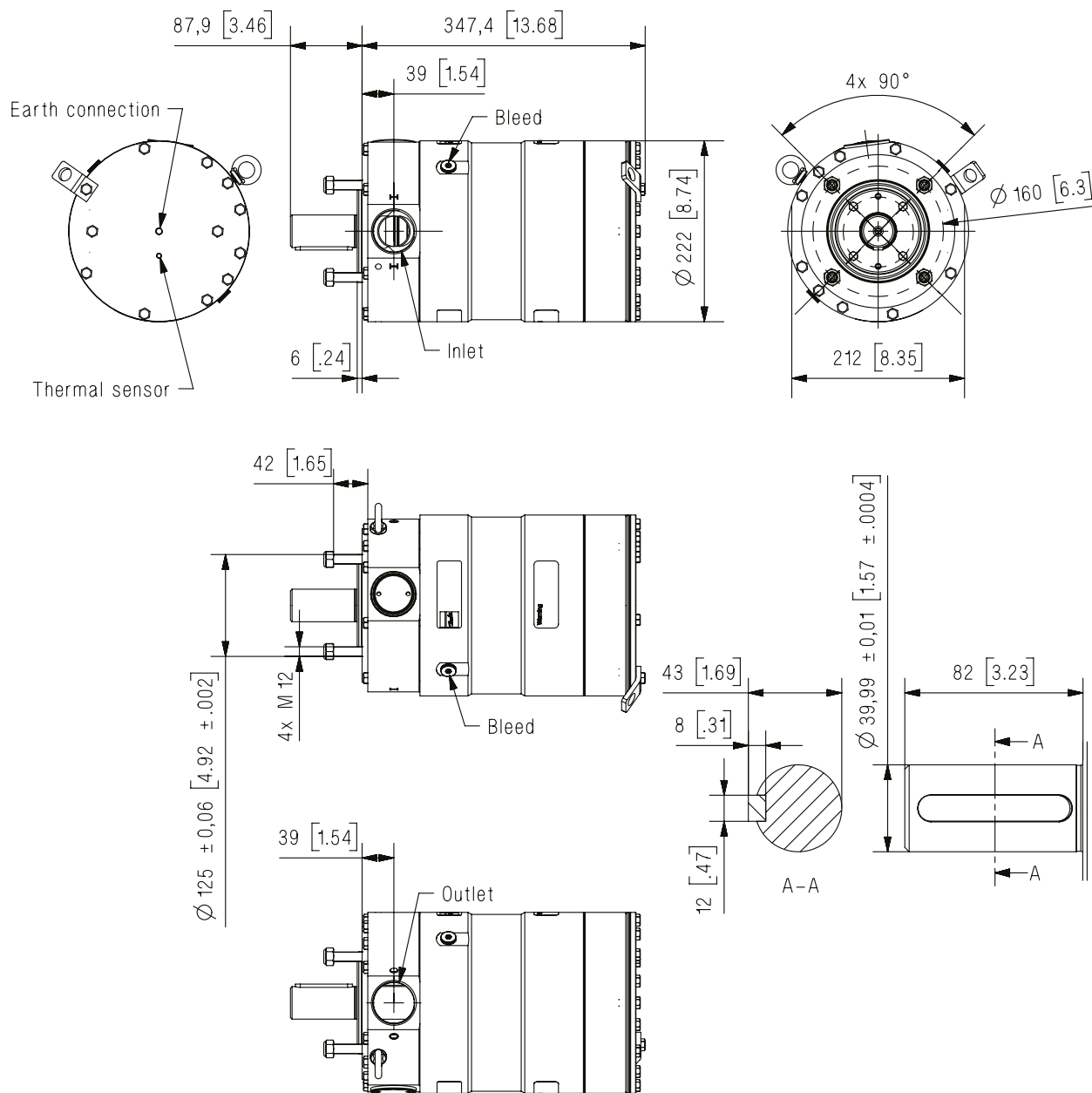

Dimensions without tolerances acc. to ISO 2768-1 designation C.

Description	APP 16-22
Parallel key, DIN 6885	12 x 8 x 70 mm 0.47 x 0.31 x 2.76 inch
Bleed	G 1/4", hex key 6 mm
Inlet port	M52x1.5; depth 21 mm
Outlet port	M52x1.5; depth 21 mm
Earth connection	M8, depth 8 mm
Thermal sensor	M6, depth 8 mm

10.6 APP 21-43

Accessories see page 33. For more details on the accessories, please contact the Danfoss High Pressure Pumps sales organisation.

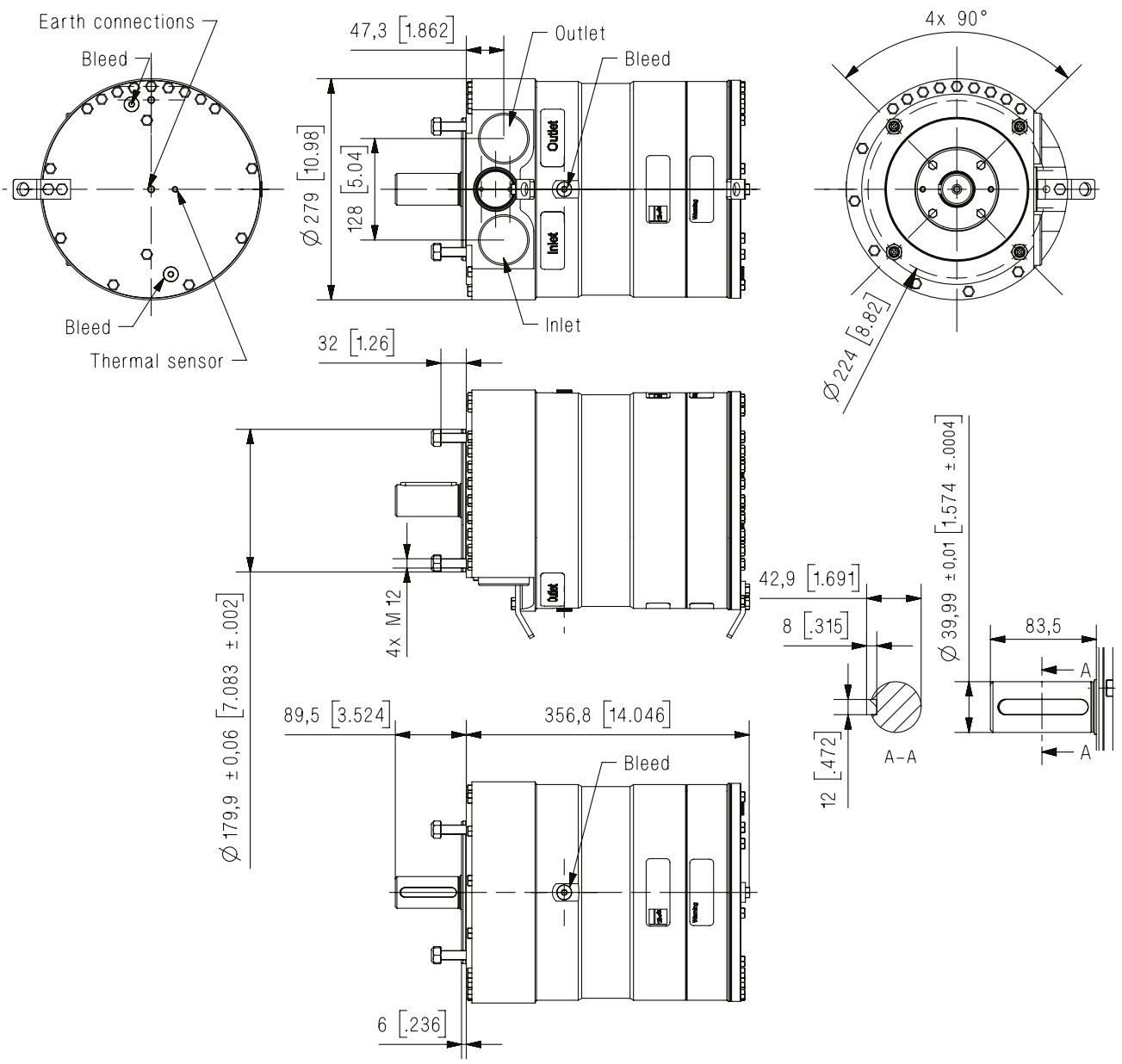

Dimensions without tolerances acc. To ISO 2768-1 designation C.

Description	APP 21-43
Parallel key, DIN 6885	12 x 8 x 70 mm 0.47 x 0.31 x 2.76 inch
Bleed	G 1/4", hex key 6 mm
Inlet port	M60x1.5; depth 23 mm
Outlet port	M60x1.5; depth 23 mm
Earth connection	M8, depth 8 mm
Thermal sensor	M6, depth 8 mm

11. Dimensions with motor 11.1 APP 0.6-3.5 unit

The examples of assemblies with motor are only for IEC motors and couplings. Please make sure to check required motor power and dimensions when selecting size of pump and motor. For advice and calculation tool, please contact Danfoss.

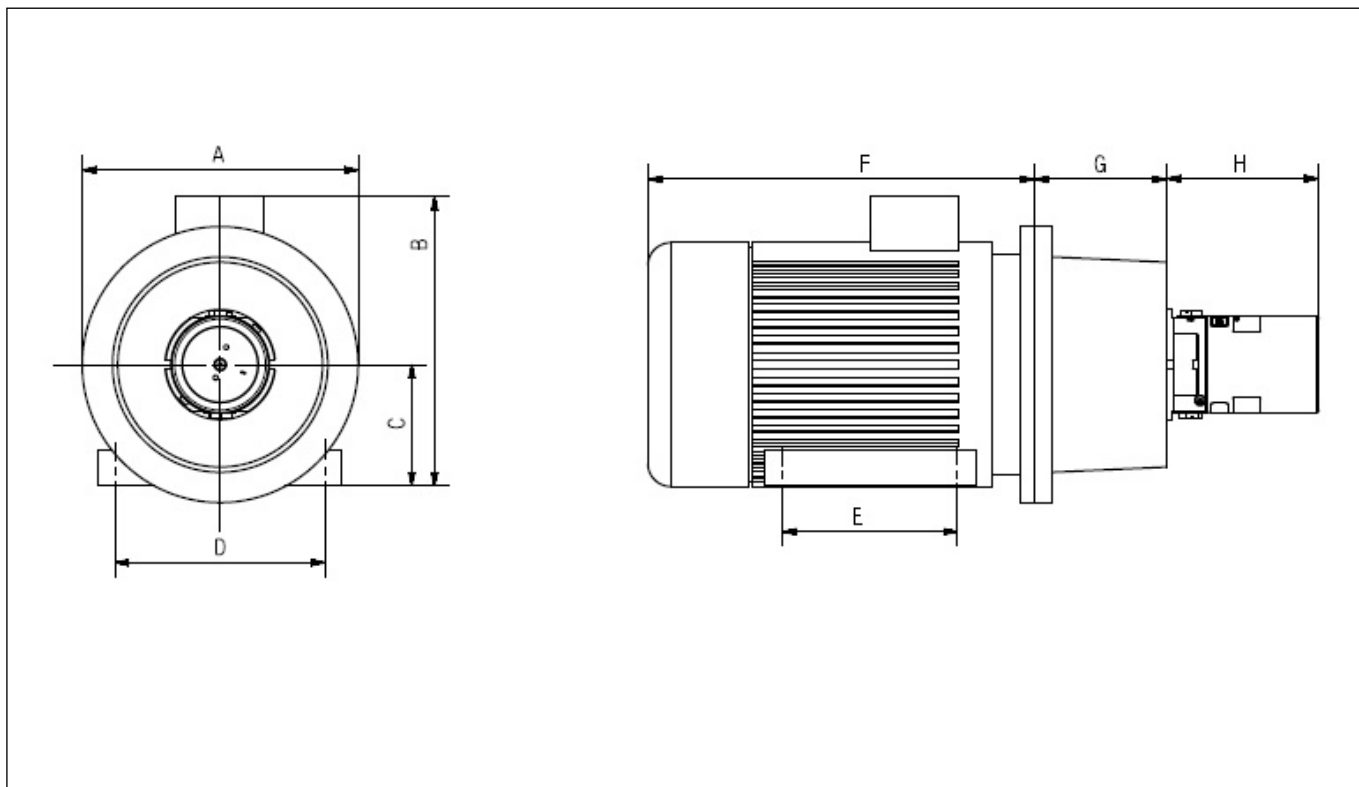

Pump	A mm (inch)	B mm (inch)	C mm (inch)	D mm (inch)	E mm (inch)	F mm (inch)	G mm (inch)	H mm (inch)	IEC Electric motor
APP 0.6	200 (7.87)	245 (9.64)	90 (3.54)	140 (5.51)	100 (3.94)	265 (10.43)	100 (3.94)	131 (5.16)	1.5 kW, IEC 90S-2
APP 0.8	200 (7.87)	245 (9.64)	90 (3.54)	140 (5.51)	125 (4.92)	290 (11.42)	100 (3.94)	131 (5.16)	2.2 kW, IEC 90L-2
APP 1.0	250 (9.84)	260 (10.23)	100 (3.94)	160 (6.30)	140 (5.51)	325 (12.80)	120 (4.72)	131 (5.16)	3.0 kW, IEC 100L-2
APP 1.5	250 (9.84)	260 (10.23)	100 (3.94)	160 (6.30)	140 (5.51)	325 (12.80)	120 (4.72)	166 (6.54)	3.0 kW, IEC 100L-2
APP 1.8	250 (9.84)	290 (11.42)	112 (4.41)	190 (7.48)	140 (5.51)	340 (13.39)	120 (4.72)	166 (6.54)	4.0 kW, IEC 112M-2
APP 2.2	300 (11.81)	338 (13.31)	132 (5.20)	216 (8.50)	140 (5.51)	403 (15.87)	144 (5.67)	166 (6.54)	5.5 kW, IEC 132S1-2
APP 2.5	300 (11.81)	338 (13.31)	132 (5.20)	216 (8.50)	178 (7.01)	403 (15.87)	144 (5.67)	166 (6.54)	7.5 kW, IEC 132S2-2
APP 3.0	350 (13.78)	422 (17.40)	160 (6.30)	254 (10.0)	210 (8.27)	505 (19.88)	188 (7.40)	166 (6.54)	11 kW, IEC 160M1-2
APP 3.5	350 (13.78)	422 (17.40)	160 (6.30)	254 (10.0)	210 (8.27)	505 (19.88)	188 (7.40)	166 (6.54)	11 kW, IEC 160M1-2

11.2 APP (W) 5.1-10.2

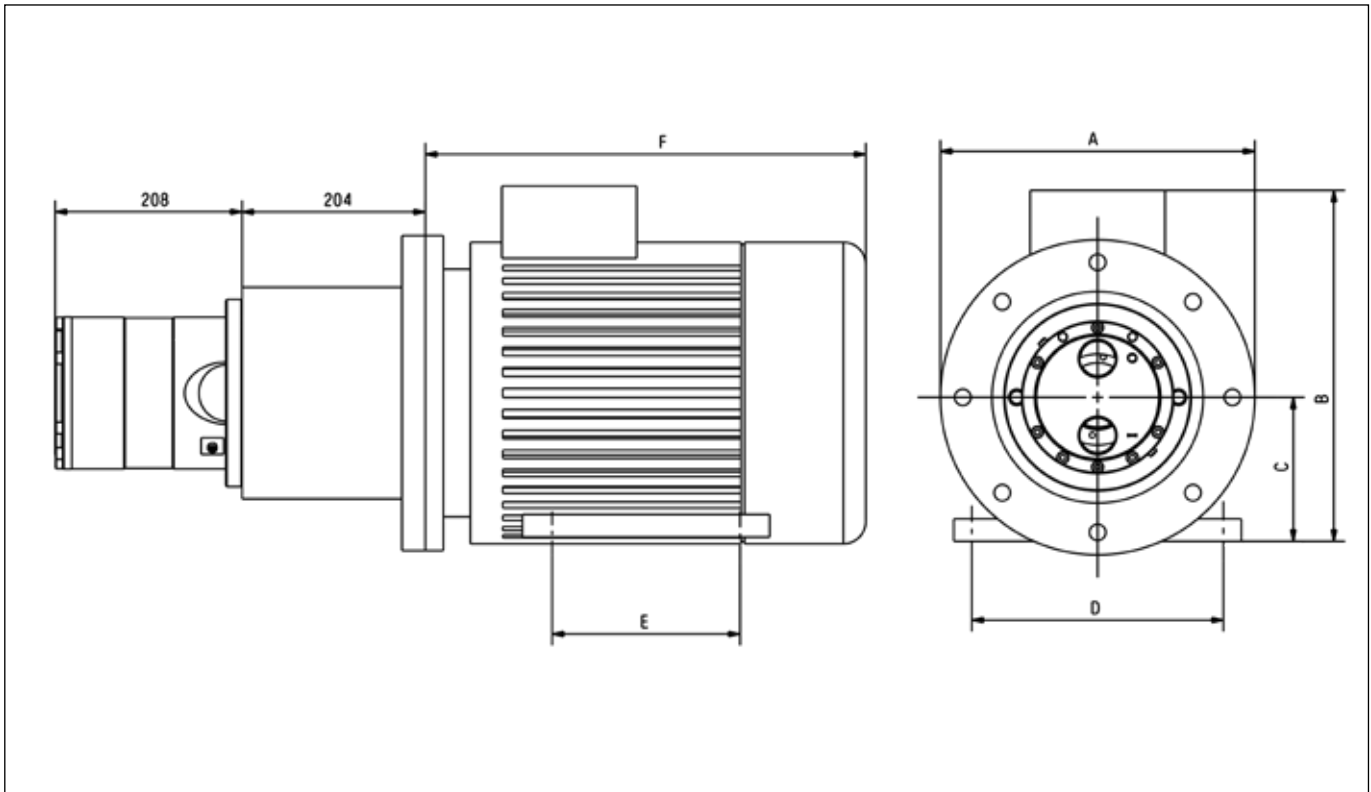

Pump	A mm (inch)	B mm (inch)	C mm (inch)	D mm (inch)	E mm (inch)	F mm (inch)	IEC Electric motor
APP 5.1	350 (13.78)	437 (17.20)	160 (6.30)	254 (10.0)	210 (8.27)	498 (19.61)	11 kW, HUC2 160 M-4
APP 6.5	350 (13.78)	437 (17.20)	160 (6.30)	254 (10.0)	254 (10.0)	542 (21.34)	15 kW, HUC2 160 L-4
APP 7.2	350 (13.78)	437 (17.20)	160 (6.30)	254 (10.0)	254 (10.0)	542 (21.34)	15 kW, HUC2 160 L-4
APP 8.2	350 (13.78)	473 (18.62)	180 (7.09)	279 (10.98)	241 (9.49)	578 (22.76)	18.5 kW, HUC2 180 M-4
APP 10.2	350 (13.78)	473 (18.62)	180 (7.09)	279 (10.98)	279 (10.98)	616 (24.25)	22 kW, HUC2 180 L-4
APP 10.2	400 (15.75)	513 (20.20)	200 (7.87)	318 (12.52)	305 (12.01)	659 (25.94)	30 kW, HUC2 200 L-4

11.3 APP 11.0-13.0

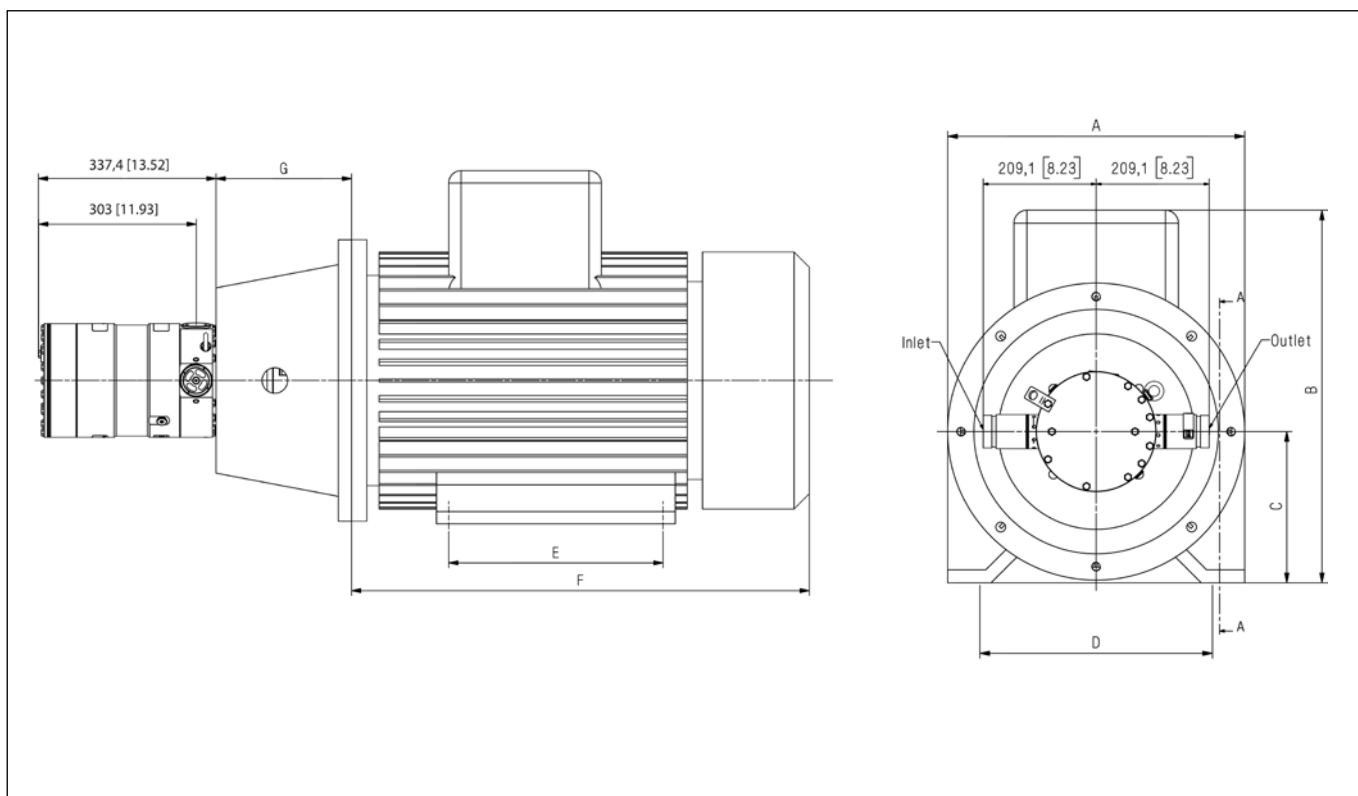

Pump	A mm (inch)	B mm (inch)	C mm (inch)	D mm (inch)	E mm (inch)	F mm (inch)	G mm (inch)	IEC Electric motor
APP 11	350 (13.78)	473 (18.62)	180 (7.09)	279 (10.98)	241 (9.49)	578 (22.76)	204 (8.03)	22 kW, IEC 180L-4
APP 11	400 (15.75)	513 (20.20)	200 (7.87)	318 (12.52)	305 (12.01)	659 (25.94)	204 (8.03)	30 kW, IEC 200L-4
APP 13	450 (17.72)	561 (22.09)	225 (8.86)	356 (14.02)	286 (11.26)	667 (26.26)	234 (9.21)	37 kW, IEC 225S-4

11.4 APP 16.0-22.0

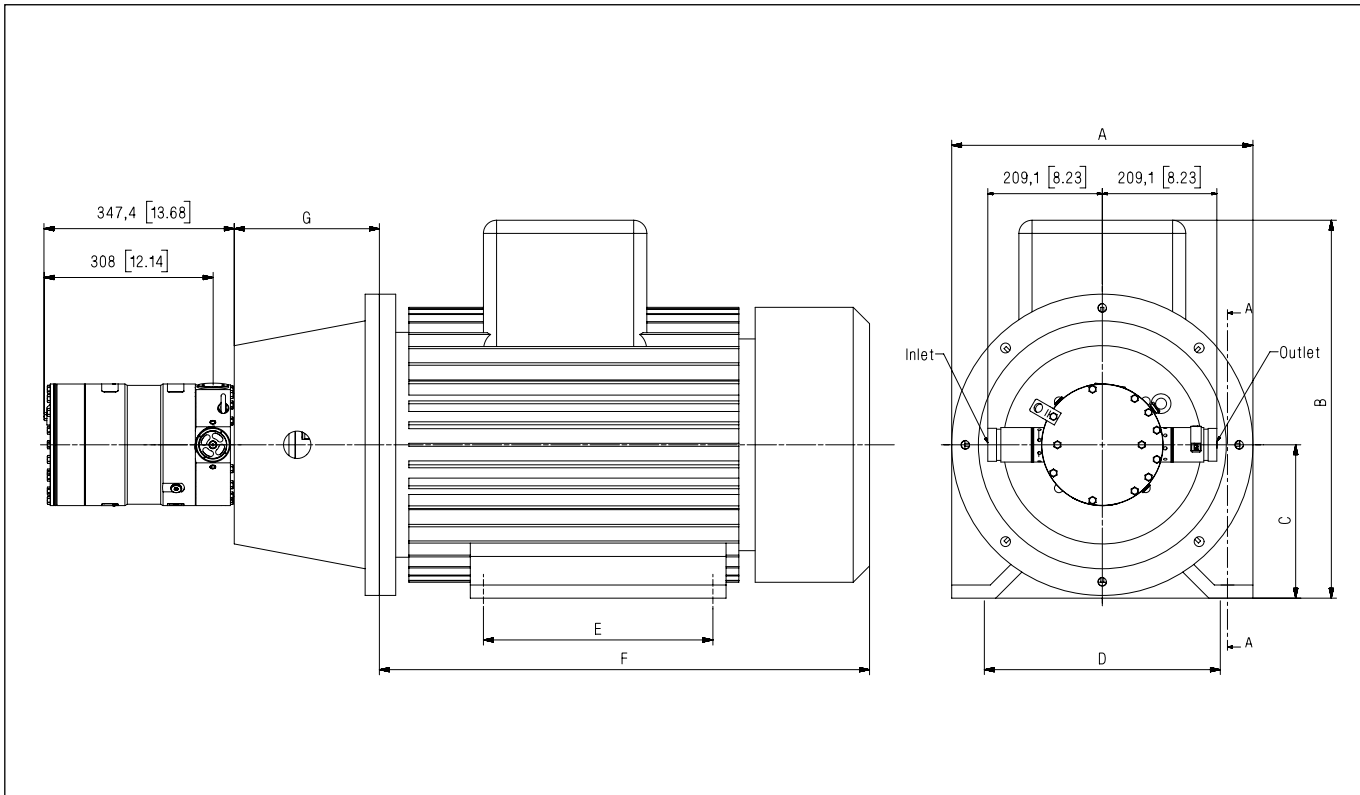

Pump	A mm (inch) [P]	B mm (inch) [HD]	C mm (inch) [H]	D mm (inch) [A]	E mm (inch) [B]	F mm (inch) [LB]	G mm (inch)	IEC Electric motor
APP 16	450 (17.72)	560 (22.05)	225 (8.86)	356 (14.02)	286 (11.26)	675 (26.57)	262 (10.31)	37 kW, IEC 225 S4
APP 17	450 (17.72)	560 (22.05)	225 (8.86)	356 (14.02)	311 (12.24)	705 (27.76)	262 (10.31)	45 kW, IEC 225 M4
APP 19	550 (21.63)	615 (24.22)	250 (9.84)	406 (15.98)	349 (13.74)	775 (30.51)	265 (10.43)	55 kW, IEC 250 M4
APP 22	550 (21.63)	680 (26.77)	280 (11.02)	457 (17.99)	368 (14.48)	835 (32.87)	265 (10.43)	75 kW, IEC 280 S4

11.5 APP 21.0-38.0

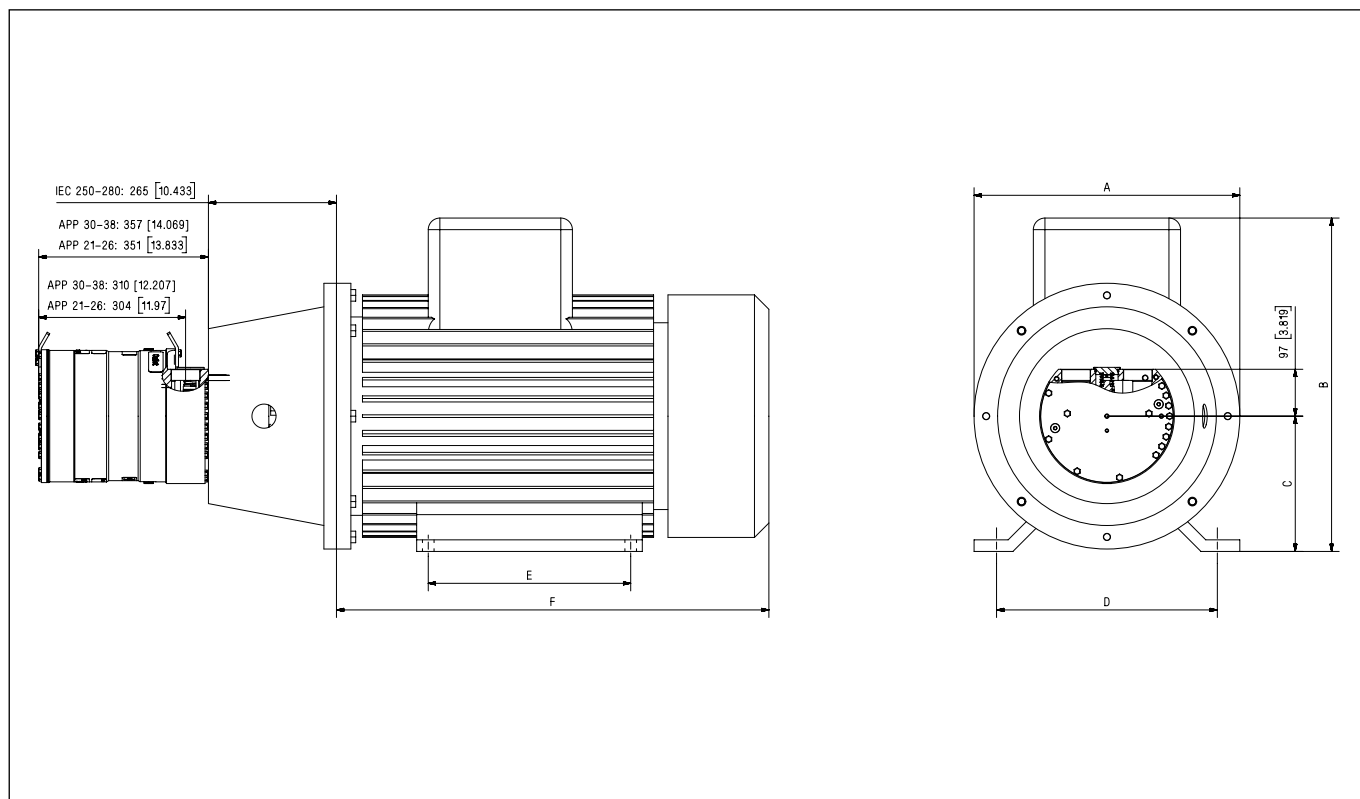

Pump	A mm (inch)	B mm (inch)	C mm (inch)	D mm (inch)	E mm (inch)	F mm (inch)	IEC Electric motor
APP 21-24	550 (21.65)	635 (25.0)	250 (9.84)	406 (15.98)	349 (13.74)	770 (30.31)	55 kW, IEC 250 M-4
APP 24-26	550 (21.65)	693 (27.28)	280 (11.02)	457 (17.99)	368 (14.49)	845 (33.27)	75 kW, IEC 280 S-4
APP 26-38	550 (21.65)	693 (27.28)	280 (11.02)	457 (17.99)	419 (16.50)	895 (35.24)	90 kW, IEC 280 M-4

11.6 APP 43

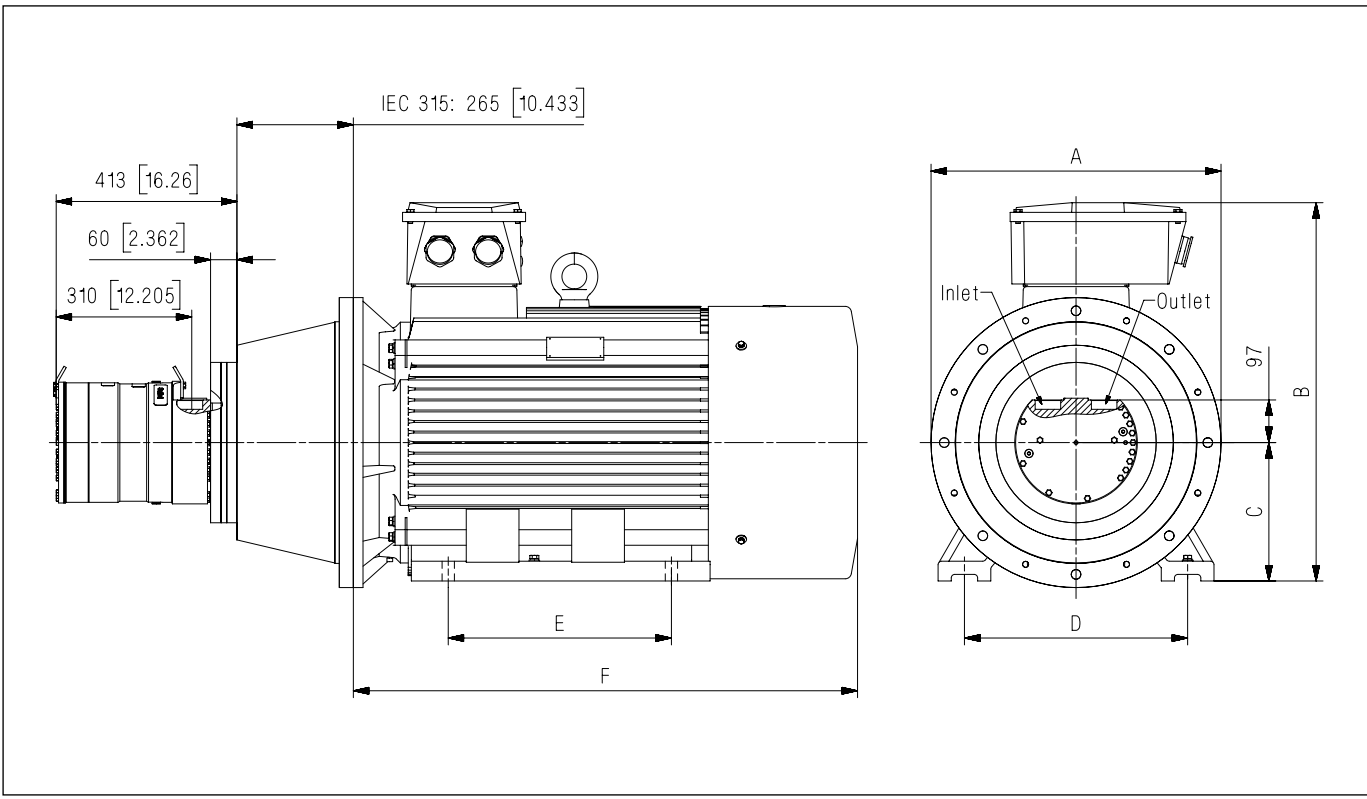

Pump	A mm (inch)	B mm (inch)	C mm (inch)	D mm (inch)	E mm (inch)	F mm (inch)	IEC Electric motor
APP 43	660 (25.98)	861 (33.90)	315 (12.40)	508 (20.00)	406 (15.98)	1038 (40.87)	110 kW, IEC 315 S-4

Due to the design and dimensions of an APP 43 pump, bell housing and IEC motor, a dampening flange on the bell housing is standard when an IEC 315 motor is selected.

If this dampening flange for some reason is deselected, an extension for the non-return valve may be needed in order to mount the pipe or hose with Victaulic clamps. For details and relevant accessories, please contact Danfoss.

12. Accessories
12.1 Accessories for APP (W) 5.1-10.2

Accessories	Type	Code No.
1" outlet hose - 0.66m (26")	1½" Victaulic	180Z0228
1" outlet hose - 1.16m (45.7")	1½" Victaulic	180Z0229
1½" inlet Vic. Duplex	M42 - 1½" Victaulic	180B3202
2" inlet hose kit - 2m (79")	2" Victaulic	180Z0298
2" inlet Vic. Super Duplex	M42 - 2" Victaulic	180Z0166
Non-return valve (outlet) Duplex	M42 - 1½" Victaulic	180H0049

12.2 Accessories for APP 11-13

Accessories	Type	Code No.
2" inlet hose kit - 2m (79")	2" Victaulic	180Z0298
1½" outlet hose - 1.16m (45.7")	1½" Victaulic	180Z0167
2" inlet Vic. Super Duplex	M42 - 2" Victaulic	180Z0166
Non-return valve (outlet) Super Duplex	M42 - 1½" Victaulic	180H0053

12.3 Accessories for APP 16-22

Accessories	Type	Code No.
2" inlet hose kit - 2m (79")	2" Victaulic	180Z0298
2" outlet hose - 1.25m (49")	2" Victaulic	180Z0140
2" inlet Vic. Super Duplex	M52 - 2" Victaulic	180Z0165
Non-return valve (outlet) Super Duplex	M52 - 2" Victaulic	180H0256

12.4 Accessories for APP 21-43

Accessories	Type	Code No.
3" inlet hose kit - 2m (79")	3" Victaulic	180Z0144
2" outlet hose APP 21-38	1.78m (70")	180Z0263
	1m (39.4")	180Z0280
2 ½" outlet hose APP 43	1m (39.4")	180Z0618
	1.78m (70")	180Z0619
2 ½" inlet connector APP 21-24	M60 - 2 ½" Victaulic	180B3206
3" inlet connector APP 21-43	M60 - 3" Victaulic	180B3208
Non-return valve (outlet) Super Duplex APP 21-43	M60 - 2 ½" Victaulic	180H0055

13. Service**Warranty**

Danfoss APP pumps are designed for long operation, low maintenance and reduced lifecycle costs.

Provided that the pump has been running according to the Danfoss specifications, Danfoss guarantees 8,000 hours service-free operation, however, max. 18 months from date of production.

If Danfoss recommendations concerning system-design are not followed, it will strongly influence the life of the APP pumps. Other factors that affect pump performance and lifetime include:

- Running the pump at speed outside specifications.
- Supplying the pump with water at temperature higher than recommended.
- Running the pump at inlet pressure outside specifications.
- Running the pump at outlet pressure outside the specifications.

Maintenance

Periodic inspections are required to ensure worn parts (if any), are replaced in due time. Operational conditions such as water quality should be taken into consideration when determining the frequency of the inspections. Danfoss recommends yearly inspections.

It is recommended to order the purpose-designed tool kit.

Pump shutdown:

The APP pumps are made of Duplex/Super Duplex materials with excellent corrosion properties. It is, however, always recommended to flush the pump with freshwater when the system is shut down.

Repair assistance

In case of irregular function of the APP pump, please contact Danfoss High Pressure Pumps.

Danfoss A/S
High Pressure Pumps
DK-6430 Nordborg
Denmark

Danfoss can accept no responsibility for possible errors in catalogues, brochures and other printed material. Danfoss reserves the right to alter its products without notice.
This also applies to products already on order provided that such alterations can be made without subsequential changes being necessary in specifications already agreed.
All trademarks in this material are property of the respective companies. Danfoss and the Danfoss logotype are trademarks of Danfoss A/S. All rights reserved.
