

Data sheet

# Modulating controlled actuators

AME 10, AME 20, AME 30

AME 13, AME 23, AME 33 - with DIN EN 14597 certified safety function (spring down)

Description

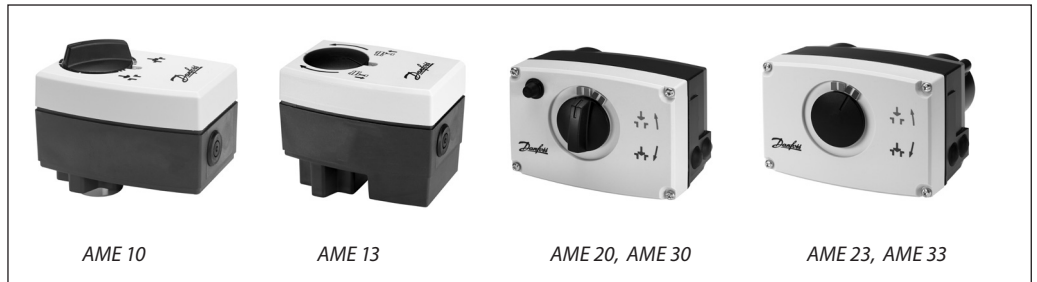

Actuators with safety function (AME 13, AME 23 or AME 33) and actuators without safety function (AME 10, AME 20 or AME 30) are mainly used with VS, VM, VB, AVQM and VMV (only with AME 10) valves.

Safety version is activated automatically in case of power failure or if the power supply is switched off by the safety thermostat. Actuators automatically adapt stroke to valve end positions which reduces commissioning time.

Actuators have some special features:

- The advanced design incorporates load related 'switch-off' to ensure that actuators and valves are not exposed to overload.
- Digital feedback end position indication signal for valve end position is available by terminal 4 or 5.
- Robust design and low weight.
- The advanced design incorporates a diagnostic LED and operational data capture,
- DIN EN 14597 certified safety function

**Main data:**

- 24 Vac version
- Force:
  - AME 10, 13 .....300 N
  - AME 20, 23, 30, 33 .....450 N
- Speed:
  - AME 10, 13 ..... 14 s/mm
  - AME 20, 23 ..... 15 s/mm
  - AME 30, 33 .....3 s/mm
- Max. medium temperature:
  - AME 10, 13 ..... 130 °C
  - AME 20, 23, 30, 33 ..... 150 °C
- End-position signals

**Note:**

The use of AME actuators together with VS2 DN 15 is not recommendable. Linear characteristics as in VS2 DN 15 valves is not recommendable in DHW production.

Ordering

**Actuators**

Type	Supply voltage	Code No.
AME 10	24 V	082G3005
AME 20		082G3015
AME 30		082G3017

**Actuators with safety function - EN 14597**

Type	Supply voltage	Code No.
AME 13	24 V	082G3006
AME 23		082G3016
AME 33		082G3018

Technical data

Type		AME 10	AME 13	AME 20	AME 23	AME 30	AME 33
Power supply	Vac	24; +10 to -15 %					
Power consumption	VA	4	9	4	9	9	14
Frequency	Hz	50/60					
Safety function		-	yes	-	yes	-	yes
Number of spring return activations		-	30.000	-	30.000	-	30.000
Safety function runtime	7 mm stroke	s	8,5	-	-	-	-
	10 mm stroke		-		8		8
Control input Y	Vdc	0-10 (2-10) Ri = 24 kΩ					
	mA	0-20 (4-20) Ri = 500 Ω					
Output signal X	Vdc	0-10 (2-10)					
Closing force	N	300		450			
Max. stroke	mm	7		10			
Speed	s/mm	14		15		3	
Max. medium temperature		130		150			
Ambient temperature	°C	0 ... 55					
Storage and transport temperature		-40 ... 70					
Ambient humidity		5-95 % r.h., non-condensing					
Protection Class		II		I (230V); III(24V)			
Grade of enclosure		IP 54					
Weight	kg	0.6	0.8	1.45	1.5	1.45	1.5
marking in accordance with standards		Low Voltage Directive (LVD) 2014/35/EU: EN 60730-1, EN 60730-2-14 Electromagnetic Compatibility Directive (EMC) 2014/30/EU: EN 61000-6-2, EN 61000-6-3					

Safety function

**Note:**  
Do not use safety activations for ON/OFF regulation.

The safety function will fully open or close the valve by power failure, depending upon the chosen safety action (SD = safety down). Valve selection will also affect the safety action. The safety function unit is factory fitted to the rear of the actuator.

Valve type	Safety action selection will	
	Close port A-AB	Open port A-AB
VS	SD <sup>1)</sup>	-
VM (DN 15-50)	SD <sup>1)</sup>	-
VB (DN 15-50)	SD <sup>1)</sup>	-
AVQM (DN 15-50)	SD <sup>1)</sup>	-
VMV	-	SD

<sup>1)</sup> in compliance with DIN EN 14597

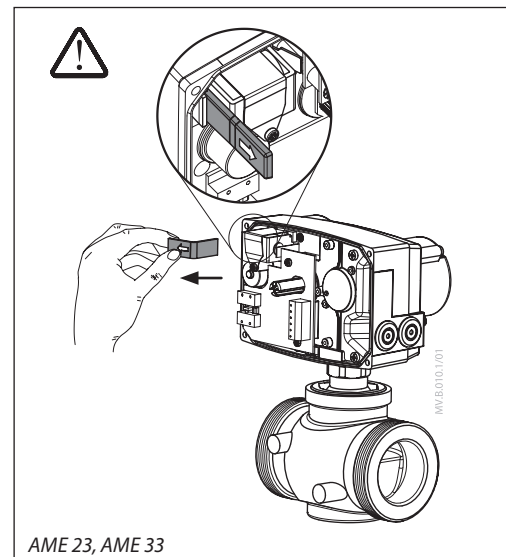
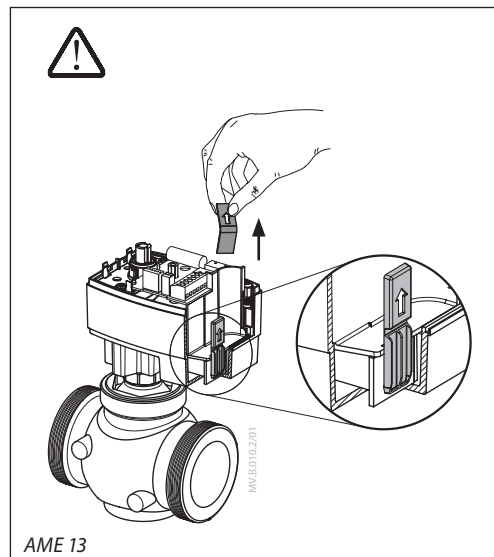
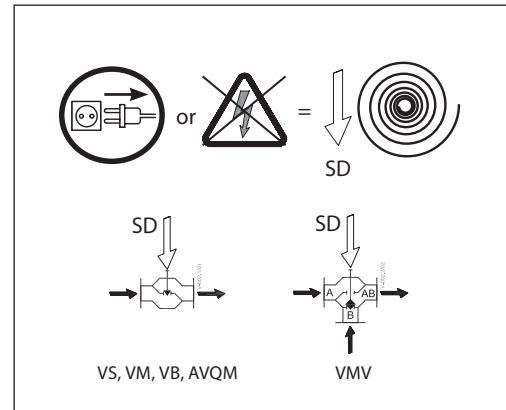

Installation

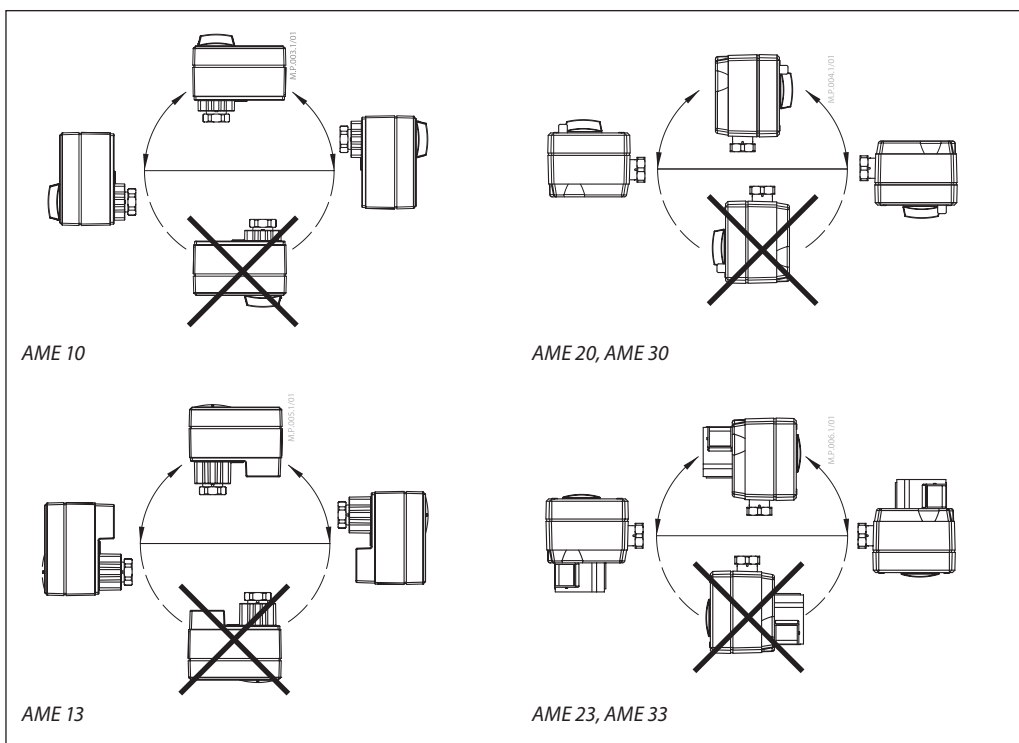

**Mechanical**

The actuator should be mounted with the valve stem in either horizontal position or pointing upwards.

The actuator is fixed to the valve body by means of a mounting ring, which requires no tools for mounting. The ring should be tightened by hand.

**Electrical**

**Important:** It is strongly recommended that the mechanical installation is completed before the electrical installation.

**Note:** Two cable entries are provided for M 16x1,5 cable glands. One entry is provided with a rubber grommet. Note that in order to maintain the enclosure's IP rating, appropriate cable glands must be used.

**Commissioning**

Complete the mechanical and electrical installation and perform the necessary checks and tests:

- Isolate control medium. (e.g. self-adjustment in a steam application without suitable mechanical isolation could cause a hazard).
- Apply the power. Note that the actuator will now perform the self-adjustment procedure.
- Apply the appropriate control signal and check the valve stem direction is correct for the application.
- Ensure that the actuator drives the valve over its full stroke, by applying the appropriate control signal. This action will set the valve stroke length.

The unit is now fully commissioned.

**Commissioning / testing feature**

The actuator can be driven to the fully open or closed positions (depending on valve type) by connecting SN to terminals 1 or 3.

Manual Override

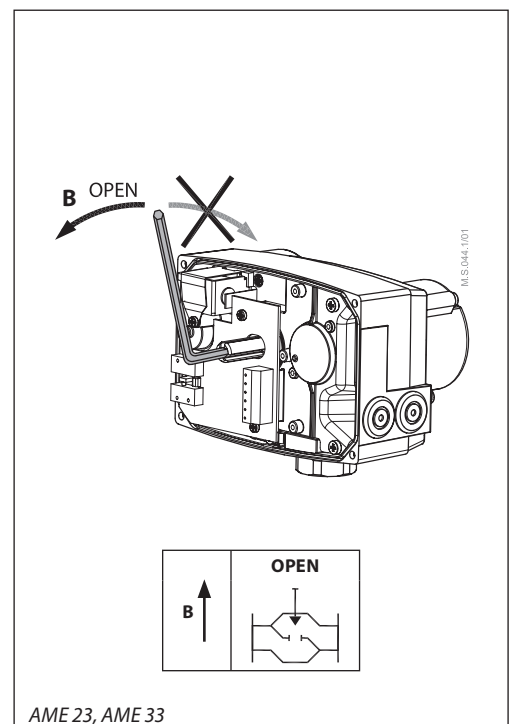
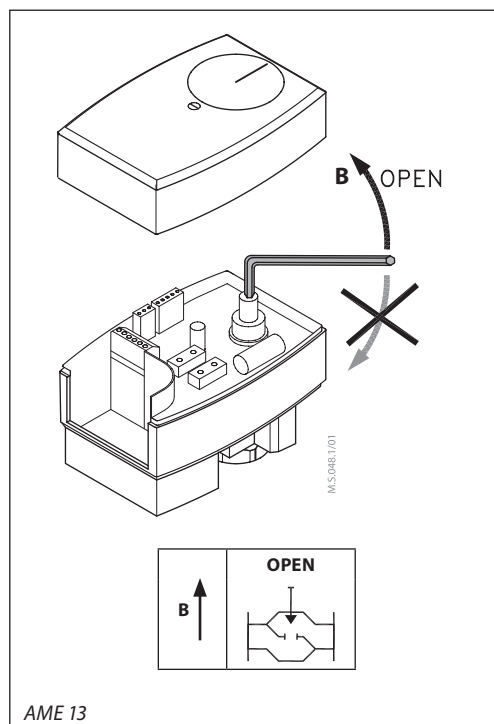
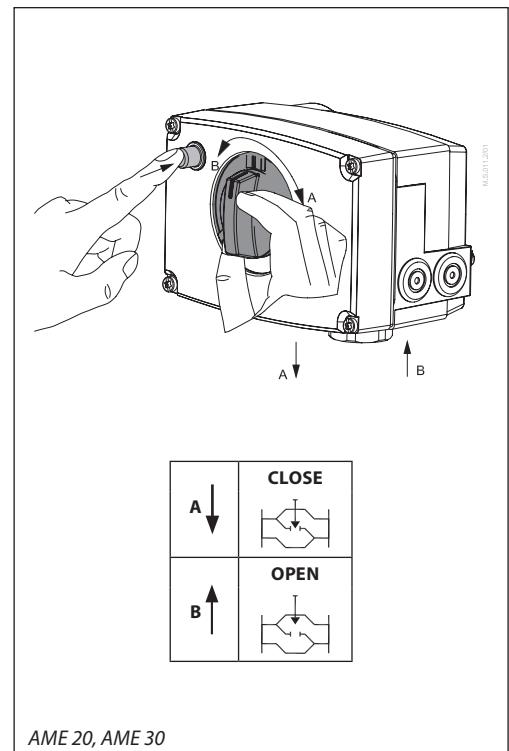
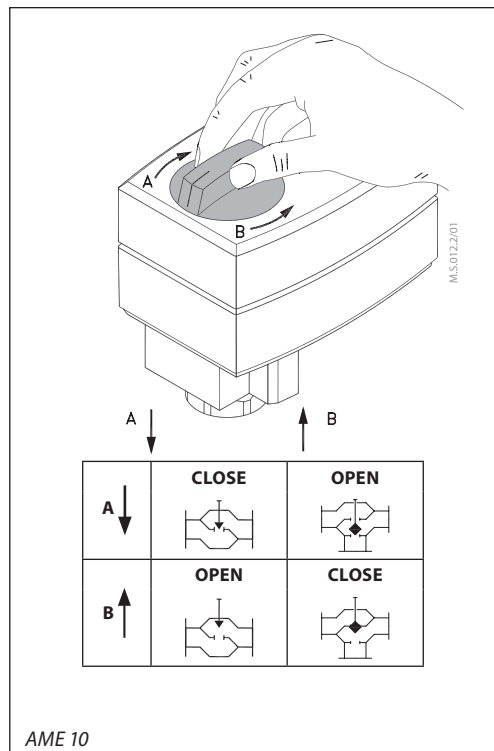

DIP switch setting

The diagram illustrates the DIP switch settings for the actuator. It shows a 9-position DIP switch bank with the following functions:

- 1: U (Voltage input)
- 2: 0...V (Voltage range)
- 3: Inverse (Actuator action)
- 4: Direct (Actuator action)
- 5: Sequential (Mode)
- 6: 5(6) ... 10V (Voltage range)
- 7: 3 point/RL (Mode)
- 8: LIN flow\* (Mode)
- 9: Red. Kvs\* (Mode)

Below the list, two diagrams show the switch bank with specific switches highlighted: the top diagram shows switches 1, 2, and 3 in the 'ON' position, and the bottom diagram shows switches 1, 2, and 4 in the 'ON' position.

Two graphs show the relationship between input voltage (0V to 10V) and current (0mA to 20mA) for different DIP 3 settings. The top graph shows 'DIP 3 = OFF (DIR)' where the current is 0mA at 0V and increases to 20mA at 10V. The bottom graph shows 'DIP 3 = ON (INV)' where the current is 20mA at 0V and decreases to 0mA at 10V.

\* Valid only for AME 13 and AME 13 SU

The actuator has a selection of DIP switches under the removable cover.

The switch provides the following functions:

**DIP1: U/I - Input signal type selector:**

- If set to OFF position, input signal Y is set to voltage (V).
- If set to ON position, input signal Y is set to be current (mA).

**DIP2: 0/2 - Input signal range selector:**

- If set to OFF position, the input signal is in the range from 2 V to 10 V (voltage input) or from 4 mA to 20 mA (current input). If set to ON position, the input signal is in the range from 0 V to 10 V (voltage input) or from 0 mA to 20 mA (current input).

**DIP3: D/I - Direct or inverse acting selector:**

- If set to OFF position, the actuator is direct acting (actuator's stem extends by voltage increase). If actuator is set to ON position the actuator is inverse acting (actuator's stem retracts by voltage increase).

**DIP4: —/Seq - Normal or sequential mode selector:**

- Two actuators can be set to work parallel with one control signal. If the SEQUENTIAL is set than an actuator responds to split control signal (see 0(2) V ... 5(6) V / 5(6) V ... 10 V).

**Note:** This combination works in combination with DIP 5:  
0(2) V ... 5(6) V / 5(6) V ... 10 V

**DIP5: 0-5 V/5-10 V - Input signal range in sequential mode:**

- This function is available if DIP 4: --- / Sequential is set. Actuator can be set to match the range of the control signal:  
2 ... 6 V (DIP 2: 2 V ... 10)  
0 ... 5 V (DIP 2: 0 V ... 10)  
4 ... 12 mA (DIP 2: 2 V ... 10)  
0 ... 10 mA (DIP 2: 0 ... 10)  
OR  
6 ... 10 V (DIP 2: 2 V ... 10)  
5 ... 10 V (DIP 2: 0 V ... 10)  
12 ... 20 mA (DIP 2: 2 V ... 10)  
10 ... 20 mA (DIP 2: 0 ... 10)

**DIP6: Prop./3-pnt - Modulating or 3-point mode selector:**

Actuator can operate in modulating (DIP 6 to OFF) or in "simple" 3-point mode, if the 3-point function is selected (DIP 6 to ON).

**Modulating mode;** DIP 6 set to OFF (factory setting)

- After the actuator has been connected to power supply, the actuator will start the self-adjustment procedure. The indicator LED flashes until self-adjustment is finished.
- Actuator's stem will run to its totally extended or retracted position by bridging SN signal to terminals 1 or 3 and will remain in this position as long as potential is present.

**It is not allowed to bridge SP to terminal 1 or 3 when DIP 6 is set to OFF.**

**3-point mode;** DIP 6 set to ON

**Look carefully wiring diagrams as wiring is different for controllers with triacs output (ECL) in comparison to controllers with relay output.**

- Connect SN (Neutral) and power supply (24Vac) via controller to terminals 1 or 3.
- Return signal X (depends on DIP 2, 3, 4 & 5) is possible if connected power supply to SP and SN.

**DIP7: LOG/LIN -** Not in use.

**DIP8: 100 % KVS/Reduced KVS -** Not in use.

**DIP9: Reset:**

- Changing this switch position will cause the actuator to go through a self-adjustment procedure.

Wiring



24 Vac only.

\* Only for actuators with safety function

**DIP 6 = OFF**      **Wiring for modulating mode**

SN	0 V	Neutral
SP	24 Vac	Power supply
Y	0(2)-10 Vdc 0(4)-20 mA	Input
1	SN	Input
3		
X	0(2)-10 Vdc	Output

Actuator needs to perform Self-adjustment prior changing DIP 6 to ON. Output signal depends on DIP 2, 3&5 setting.

\* Only for actuators with safety function

**DIP 6 = ON**      **Wiring for 3-point floating mode / Controller with relay output**

SN	0 V	Neutral
SP	24 Vac	Power supply
1	SP	Input
3		
X	0(2)-10 Vdc	Output

**DIP 6 = ON**      **Wiring for 3-point floating mode / Controller with triacs output**

SN	0 V	Neutral
SP	24 Vac	Power supply
1	SP	Input
3		
X	0(2)-10 Vdc	Output

\* Only for actuators with safety function  
 \*\*R1, \*\*R2=2.6 kΩ (0.5W)

**Automatic self-adjustment feature**

When power is first applied, the actuator will automatically adjust to the length of the valve stroke. Subsequently, the self-adjustment feature can be re-initialised by changing position of SW9.

Wiring length	Recommended square of the wiring
0-50 m	0.75 mm <sup>2</sup>
> 50 m	1.5 mm <sup>2</sup>

**Diagnostic LED**

The red diagnostic LED is located on the pcb under the cover. It provides indication of three operational states:

- Actuator Healthy (Permanently ON),
- Self Stroking (Flashes once per second),
- Error (Flashes 3 times per second - seek technical assistance).

Dimensions

AME 10

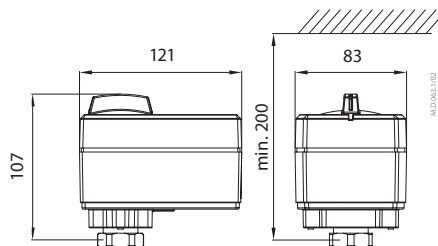

AME 13

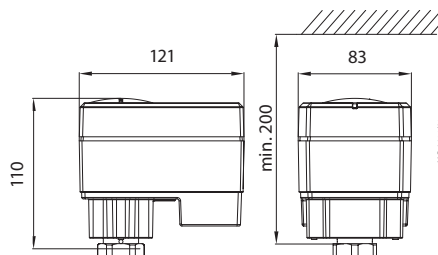

AME 20, AME 30

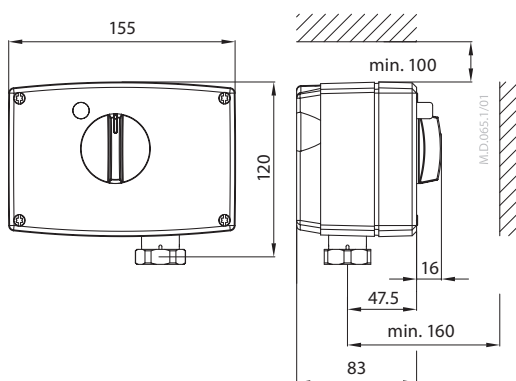

AME 23, AME 33

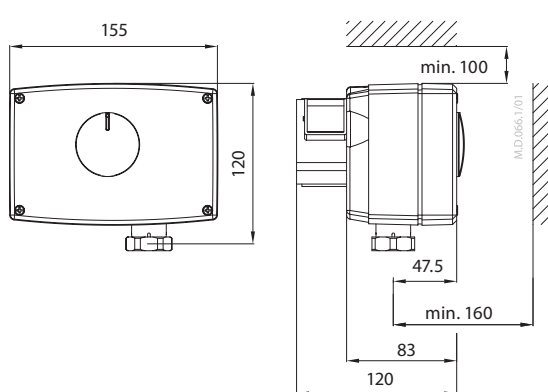

Actuator - valve combinations

**AME 10, AME 13 + VS2 (DN 20\* - 25) VM2 (DN 15 - 32)**  
**AME 10, AME 13 + VB2 (DN 15 - 25)**  
**AME 10 + VMV (DN 15 - 40)**  
**AME 10, AME 13 + AVQM (see AVQM data sheet)**

**AME 20/30, AME 23/33 + VS2 (DN 20\* - 25) VM2 (DN 15 - 50)**  
**AME 20/30, AME 23/33 + VB2 (DN 15 - 50)**  
**AME 20/30, AME 23/33 + AVQM (see AVQM data sheet)**

*\*The use of AME actuators together with VS2 DN 15 is not recommendable. Linear characteristics as in VS2 DN 15 valves is not recommendable in DHW production.*

Danfoss A/S

Climate Solutions • danfoss.com • +45 7488 2222

Any information, including, but not limited to information on selection of product, its application or use, product design, weight, dimensions, capacity or any other technical data in product manuals, catalogues descriptions, advertisements, etc. and whether made available in writing, orally, electronically, online or via download, shall be considered informative, and is only binding if and to the extent, explicit reference is made in a quotation or order confirmation. Danfoss cannot accept any responsibility for possible errors in catalogues, brochures, videos and other material. Danfoss reserves the right to alter its products without notice. This also applies to products ordered but not delivered provided that such alterations can be made without changes to form, fit or function of the product.

All trademarks in this material are property of Danfoss A/S or Danfoss group companies. Danfoss and the Danfoss logo are trademarks of Danfoss A/S. All rights reserved.