

Maintenance Aid

# AmaSlide

## Installation/Operating Manual



Mat. No.: 05040252

## **Legal information/Copyright**

Installation/Operating Manual AmaSlide

Original operating manual

All rights reserved. The contents provided herein must neither be distributed, copied, reproduced, edited or processed for any other purpose, nor otherwise transmitted, published or made available to a third party without the manufacturer's express written consent.

Subject to technical modification without prior notice.

© KSB SE & Co. KGaA, Frankenthal 04/05/2020

## Contents

	<b>Glossary .....</b>	<b>5</b>
<b>1</b>	<b>General.....</b>	<b>6</b>
	1.1 Principles .....	6
	1.2 Target group.....	6
	1.3 Other applicable documents.....	6
	1.4 Symbols .....	6
	1.5 Key to safety symbols/markings.....	6
<b>2</b>	<b>Safety .....</b>	<b>8</b>
	2.1 General.....	8
	2.2 Intended use .....	8
	2.3 Personnel qualification and personnel training .....	8
	2.4 Consequences and risks caused by non-compliance with these operating instructions .....	8
	2.5 Safety awareness .....	9
	2.6 Safety information for the user/operator .....	9
	2.7 Safety information for maintenance, inspection and installation .....	9
	2.8 Unauthorised modes of operation .....	9
<b>3</b>	<b>Transport/Storage/Disposal .....</b>	<b>10</b>
	3.1 Checking the condition upon delivery .....	10
	3.2 Transport.....	10
	3.3 Storage/preservation .....	10
	3.4 Return to supplier.....	11
	3.5 Disposal .....	12
<b>4</b>	<b>Description.....</b>	<b>13</b>
	4.1 General description .....	13
	4.2 Designation.....	13
	4.3 Name plate.....	13
	4.4 Configuration and function.....	14
	4.5 Scope of supply.....	14
	4.6 Dimensions and weights .....	14
<b>5</b>	<b>Installation at Site .....</b>	<b>15</b>
	5.1 Safety regulations.....	15
	5.2 Checks to be carried out prior to installation.....	15
	5.3 Installing a pump set with AmaSlide.....	16
<b>6</b>	<b>Operation.....</b>	<b>21</b>
	6.1 Safety regulations.....	21
	6.2 Moving the maintenance aid into servicing position.....	22
	6.3 Moving the maintenance aid into operating position.....	23
<b>7</b>	<b>Servicing/Maintenance .....</b>	<b>24</b>
	7.1 Safety regulations.....	24
	7.2 Maintenance/inspection.....	24
	7.3 Cleaning .....	24
	7.4 Tightening torques.....	25
	7.5 Spare parts stock.....	25
	7.5.1 Ordering spare parts.....	25
<b>8</b>	<b>Related Documents .....</b>	<b>26</b>
	8.1 General assembly drawings with list of components.....	26
	8.1.1 AmaSlide.....	26
	8.2 Combinations of pump and maintenance aid .....	27

<b>9</b>	<b>Certificate of Decontamination.....</b>	<b>30</b>
	<b>Index .....</b>	<b>31</b>

## Glossary

### Certificate of decontamination

A certificate of decontamination is enclosed by the customer when returning the product to the manufacturer to certify that the product has been properly drained to eliminate any environmental and health hazards arising from components in contact with the fluid handled.

## 1 General

### 1.1 Principles

This operating manual is valid for the type series and variants indicated on the front cover.

The operating manual describes the proper and safe use of this equipment in all phases of operation.

In the event of damage, immediately contact your nearest KSB service facility to maintain the right to claim under warranty.

### 1.2 Target group

This operating manual is aimed at the target group of trained and qualified specialist technical personnel.

### 1.3 Other applicable documents

**Table 1:** Overview of other applicable documents

Document	Contents
Data sheet	Description of the technical data of the pump (set)
General arrangement drawing/ outline drawing	Description of mating dimensions and installation dimensions for the pump (set), weights
General assembly drawing <sup>1)</sup>	Sectional drawing of the product
List of components <sup>1)</sup>	Description of all components
Installation/operating manual of the pump	Proper and safe use of the pump in all phases of operation



### 1.4 Symbols

**Table 2:** Symbols used in this manual





Symbol	Description
✓	Conditions which need to be fulfilled before proceeding with the step-by-step instructions
▷	Safety instructions
⇒	Result of an action
⇔	Cross-references
1. 2.	Step-by-step instructions
	Note Recommendations and important information on how to handle the product

### 1.5 Key to safety symbols/markings

**Table 3:** Definition of safety symbols/markings

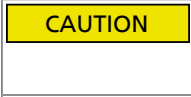
Symbol	Description
 <b>DANGER</b>	<b>DANGER</b> This signal word indicates a high-risk hazard which, if not avoided, will result in death or serious injury.
 <b>WARNING</b>	<b>WARNING</b> This signal word indicates a medium-risk hazard which, if not avoided, could result in death or serious injury.

1) If agreed to be included in the scope of supply

Symbol	Description
	<p><b>CAUTION</b> This signal word indicates a hazard which, if not avoided, could result in damage to the machine and its functions.</p>
	<p><b>General hazard</b> In conjunction with one of the signal words this symbol indicates a hazard which will or could result in death or serious injury.</p>
	<p><b>Electrical hazard</b> In conjunction with one of the signal words this symbol indicates a hazard involving electrical voltage and identifies information about protection against electrical voltage.</p>
	<p><b>Machine damage</b> In conjunction with the signal word CAUTION this symbol indicates a hazard for the machine and its functions.</p>



## 2 Safety

All the information contained in this section refers to hazardous situations.

In addition to the present general safety information the action-related safety information given in the other sections must be observed.

### 2.1 General

- This operating manual contains general installation, operating and maintenance instructions that must be observed to ensure safe operation of the system and prevent personal injury and damage to property.
- Comply with all the safety instructions given in the individual sections of this operating manual.
- The operating manual must be read and understood by the responsible specialist personnel/operators prior to installation and commissioning.
- The contents of this operating manual must be available to the specialist personnel at the site at all times.
- The operator is responsible for ensuring compliance with all local regulations not taken into account.

### 2.2 Intended use

- Maintenance aids must only be used within the limits described in this installation/operating manual.
- Only use maintenance aids which are in perfect technical condition.
- Consult the manufacturer about any other modes of use not described in the data sheet or product literature.
- Never exceed the permissible application and operating limits specified in the data sheet or product literature regarding temperature, etc.
- Observe all safety information and instructions in this manual.

### 2.3 Personnel qualification and personnel training

All personnel involved must be fully qualified to transport, operate, maintain and inspect the equipment this manual refers to. The responsibilities, competence and supervision of all personnel involved in operation, maintenance and inspection must be clearly defined by the operator.

Deficits in knowledge must be rectified by means of training and instruction provided by sufficiently trained specialist personnel. If required, the operator can commission the manufacturer/supplier to train the personnel.

Training on the product must always be supervised by specialist technical personnel.

### 2.4 Consequences and risks caused by non-compliance with these operating instructions

- Non-compliance with these operating instructions will lead to forfeiture of warranty cover and of any and all rights to claims for damages.
- Non-compliance can, for example, have the following consequences:
  - Risk of load or lifting accessory components falling down
  - Risk of lifting accessories tipping over if positioned on inclined surfaces and/or if not in a sufficiently stable position
  - Risk of crushing and shearing injuries by moving parts or by parts under tension
  - Risk to health and environment from hazardous fluids or substances
  - Failure of important product functions



### 2.5 Safety awareness

In addition to the safety information contained in this operating manual and the intended use, the following safety regulations shall be complied with:

- Accident prevention, health regulations and safety regulations
- Explosion protection regulations
- Safety regulations for handling hazardous substances
- Applicable standards, directives and laws

### 2.6 Safety information for the user/operator

- Provide the personnel with protective equipment and make sure it is used.
- Contain any residues of hazardous fluids (e.g. explosive, toxic, hot) so as to avoid any danger to persons and the environment. Observe all legal requirements.

### 2.7 Safety information for maintenance, inspection and installation

- Modifications or alterations of the product are only permitted with the manufacturer's prior consent.
- Use only original spare parts or parts/components authorised by the manufacturer. The use of other parts/components can invalidate any liability of the manufacturer for resulting damage.
- The operator ensures that maintenance, inspection and installation are performed by authorised, qualified specialist personnel who are thoroughly familiar with the manual.
- Carry out all work at the product in the designated work area.
- The product must have cooled down to ambient temperature.
- Decontaminate products which have been used in fluids posing a health hazard.

### 2.8 Unauthorised modes of operation

Never operate the product outside the limits stated in the data sheet and in this manual.

The warranty relating to the operating reliability and safety of the product supplied is only valid if the product is used in accordance with its intended use.

### 3 Transport/Storage/Disposal

#### 3.1 Checking the condition upon delivery

1. On transfer of goods, check each packaging unit for damage.
2. In the event of in-transit damage, assess the exact damage, document it and notify KSB or the supplying dealer and the insurer about the damage in writing immediately.

#### 3.2 Transport

	<b>⚠ DANGER</b>
	<p><b>Improper transport</b>            Danger to life from falling parts!            Damage to the pump set!</p> <ul style="list-style-type: none"> <li>▷ Use tested, marked and approved lifting accessories only.</li> <li>▷ The load-carrying capacity of the lifting accessory must be greater than the weight indicated on the name plate of the product to be lifted.</li> <li>▷ Use the attachment point provided for attaching the lifting accessory.</li> <li>▷ Never suspend the pump set by its power cable.</li> <li>▷ Never enter the area underneath suspended load.</li> <li>▷ Observe the regional transport regulations.</li> </ul>
	<b>⚠ DANGER</b>
	<p><b>Improper transport</b>            Risk of injury from lifting heavy components!</p> <ul style="list-style-type: none"> <li>▷ Select lifting accessories which are suitable for the component weight.</li> <li>▷ Always use the attachment points provided for the lifting accessories.</li> <li>▷ Comply with the applicable health and safety regulations.</li> </ul>

#### Transport on pallet

Transport the maintenance aid or the pump set with fitted maintenance aid using a forklift truck or pallet truck of sufficient load-carrying capacity.

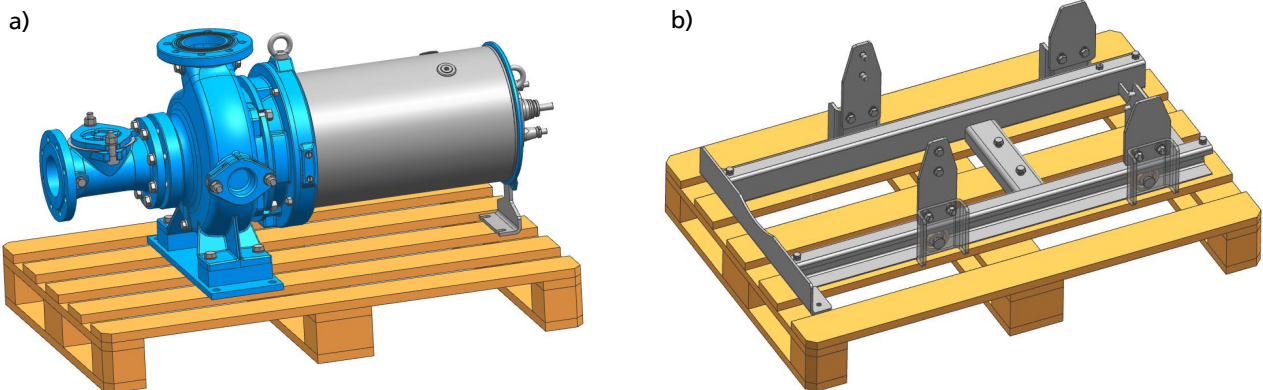

Fig. 1: Transport on pallet a) Pump set (suction-side flanged spacer optional) without b) Maintenance aid

The maintenance aid is assembled and installed at the customer's site. The bolting or chemical anchors are supplied in a separate packaging unit.

#### 3.3 Storage/preservation

**Storage** If the ambient conditions for storage are met, the function of the maintenance aid is safeguarded even after a prolonged period of storage.

**Table 4:** Ambient conditions for storage

Ambient condition	Value	
Relative humidity	Max. 85 % (non-condensing)	
Ambient temperature	-20 °C to +80 °C	-4 °F to +176 °F

- Store the maintenance aid in dry, vibration-free conditions, and protect it against the weather.
- Store the maintenance aid in a dry room in which the atmospheric humidity is maintained at a constant level.
- Prevent excessive fluctuations in atmospheric humidity (see table Ambient conditions for storage).

If stored properly, the product will be protected for a maximum of 12 months.

**Preservation** Preservation will protect the maintenance aid against corrosion if it is stored or taken out of service for a prolonged period of time.

	<p><b>! WARNING</b></p>
	<p><b>Fluids, consumables and supplies posing a health hazard</b> Hazard to persons and the environment!</p> <ul style="list-style-type: none"> <li>▷ Collect and dispose of any preservatives, flushing liquids and fluid residues.</li> <li>▷ Wear safety clothing and a protective mask, if required.</li> <li>▷ Observe all legal regulations on the disposal of fluids posing a health hazard.</li> </ul>
	<p><b>NOTE</b></p>
	<p>Observe the manufacturer's instructions for application/removal of the preservative.</p>

1. Thoroughly clean the maintenance aid.
2. Apply the preservative evenly.

**Removal of preservation** Preservatives must be removed from the maintenance aid prior to commissioning.

	<p><b>! WARNING</b></p>
	<p><b>Fluids, consumables and supplies posing a health hazard</b> Hazard to persons and the environment!</p> <ul style="list-style-type: none"> <li>▷ Collect and dispose of any preservatives, flushing liquids and fluid residues.</li> <li>▷ Wear safety clothing and a protective mask, if required.</li> <li>▷ Observe all legal regulations on the disposal of fluids posing a health hazard.</li> </ul>
	<p><b>NOTE</b></p>
	<p>Observe the manufacturer's instructions for application/removal of the preservative.</p>

### 3.4 Return to supplier

1. Prior to returning the product to the supplier, flush and clean it, particularly if it has been used in noxious, explosive, hot or other hazardous fluids.
2. If the product has been used in fluids whose residues could lead to corrosion damage in the presence of atmospheric humidity or could ignite upon contact with oxygen, the product must also be neutralised and treated with anhydrous inert gas to ensure drying.
3. Always complete and enclose a certificate of decontamination when returning the product. (⇒ Section 9, Page 30)  
Indicate any safety measures and decontamination measures taken.

	<b>NOTE</b>
	<p>If required, a blank certificate of decontamination can be downloaded from the following web site: <a href="http://www.ksb.com/certificate_of_decontamination">www.ksb.com/certificate_of_decontamination</a></p>

### 3.5 Disposal

	<b>WARNING</b>
	<p><b>Fluids, consumables and supplies posing a health hazard</b>  Hazard to persons and the environment!</p> <ul style="list-style-type: none"> <li>▷ Collect and dispose of any preservatives, flushing liquids and fluid residues.</li> <li>▷ Wear safety clothing and a protective mask, if required.</li> <li>▷ Observe all legal regulations on the disposal of fluids posing a health hazard.</li> </ul>

1. Dismantle the product.  
Collect greases and other lubricants during dismantling.
2. Separate and sort the materials, e.g. by:
  - Metals
  - Plastics
  - Electronic waste
  - Greases and other lubricants
3. Dispose of materials in accordance with local regulations or in another controlled manner.

## 4 Description

### 4.1 General description

- Maintenance aid

Maintenance aids serve to carry out maintenance/servicing work and inspections on KSB pump sets. The maintenance aid does away with the need for a crane for maintenance/servicing/inspection work.

### 4.2 Designation

**Example: AmaSlide KB16-AH280**

**Table 5:** Designation key

Code	Description
AmaSlide	Type series
KB16	Motor size
AH280	Pump centreline height

### 4.3 Name plate

The maintenance aid does not have a name plate of its own as the maintenance aid is usually fitted to the pump set at the customer's site. A maintenance aid retrofitted to an existing pump can be identified as a pre-assembled delivery unit by the order number.

### 4.4 Configuration and function

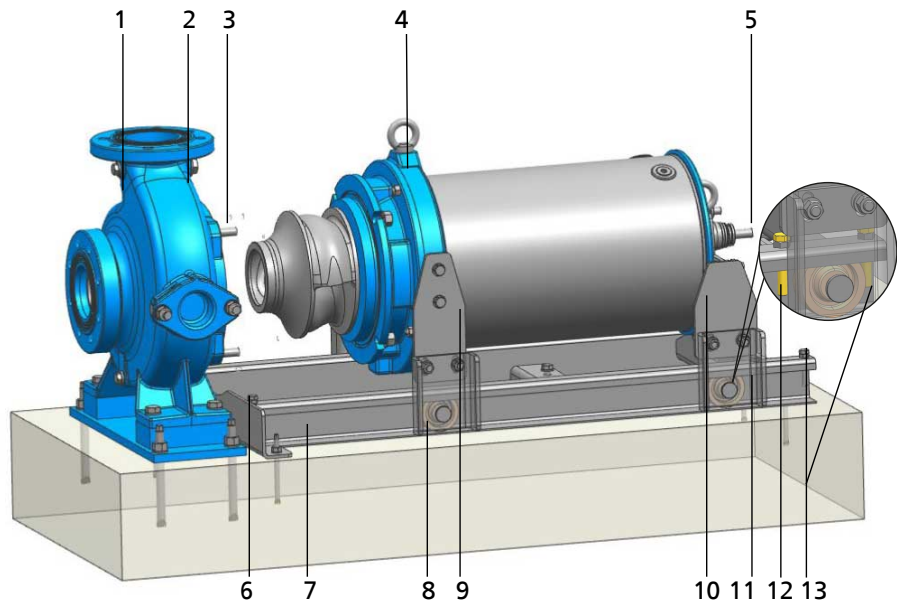

Fig. 2: AmaSlide in servicing position

1	Pump set	8	Guide plate with roller
2	Pump casing	9	Adapter, pump end
3	Fastener, discharge cover	10	Adapter, motor end
4	Back pull-out unit	11	Guide plate with roller
5	Power cable	12	Locking bolt in servicing position
6	Locking bolt in operating position	13	Locking bolt in servicing position
7	Guide rail		

**Design** AmaSlide is a maintenance aid for horizontally dry-installed pump sets (1) of the Amarex KRT type series.

**Function** After the discharge cover fasteners (3) have been removed from the pump casing (2), the entire back pull-out unit (4) including motor can be removed from the pump casing (2).

The back pull-out unit (4) including motor can be moved along the guide rails (7) until it reaches the servicing position. Remove and re-position the locking bolts (6), see locking bolts (12). The guide plates (11) are locked in the axial direction with the locking bolts (12) and (13).

This (servicing) position is suitable for the following work:

- Inspecting the pump casing
- Removing any solids/stringy substances
- Checking for wear and replacing casing wear ring or wear plate if required
- Checking the O-rings at the discharge cover and replacing them if required
- Checking the impeller and discharge cover and replacing them if required
- Replacing the mechanical seal

### 4.5 Scope of supply

Depending on the model, the following items are included in the scope of supply:



- Maintenance aid

### 4.6 Dimensions and weights



For dimensions and weights refer to the overview "Combinations of pumps and maintenance aids".

## 5 Installation at Site



### 5.1 Safety regulations

	 <b>DANGER</b>
	<p><b>Improper installation in potentially explosive atmospheres</b>            Damage to the pump set!</p> <ul style="list-style-type: none"> <li>▷ Comply with the applicable local explosion protection regulations.</li> <li>▷ Observe the information given in the data sheet and on the pump/motor name plates.</li> </ul>

### 5.2 Checks to be carried out prior to installation

	 <b>WARNING</b>
	<p><b>Improper installation of the pump set</b>            Personal injury and damage to property!</p> <ul style="list-style-type: none"> <li>▷ Observe the following instructions for positioning and installing the pump set to prevent substantial hazards and injuries.</li> </ul>

#### Place of installation

	 <b>WARNING</b>
	<p><b>Installation on mounting surface which is unsecured and cannot support the load</b>            Personal injury and damage to property!</p> <ul style="list-style-type: none"> <li>▷ Use a concrete of compressive strength class C12/15 which meets the requirements of exposure class XC1 to EN 206-1.</li> <li>▷ The mounting surface must be set, flat, and level.</li> <li>▷ Observe the weights indicated.</li> </ul>

1. Check the structural requirements.  
 All structural work required must have been prepared in accordance with the dimensions to ensure the maintenance aid can be moved into servicing position.  
 (⇒ Section 8.2, Page 27)

#### Power cable

	<b>CAUTION</b>
	<p><b>Power cable not properly routed</b>            Damage to the power cable!</p> <ul style="list-style-type: none"> <li>▷ The power cable must be routed in such a way that it cannot become damaged when the maintenance aid is operated.              Observe the dimensions indicated. (⇒ Section 8.2, Page 27)</li> </ul>

1. Check the position of the power cable.  
 The power cable must be positioned so as not to obstruct the back pull-out unit when it is moved from the operating position to the servicing position.

### 5.3 Installing a pump set with AmaSlide

Install the pump set as described in the pump's installation/operating manual.

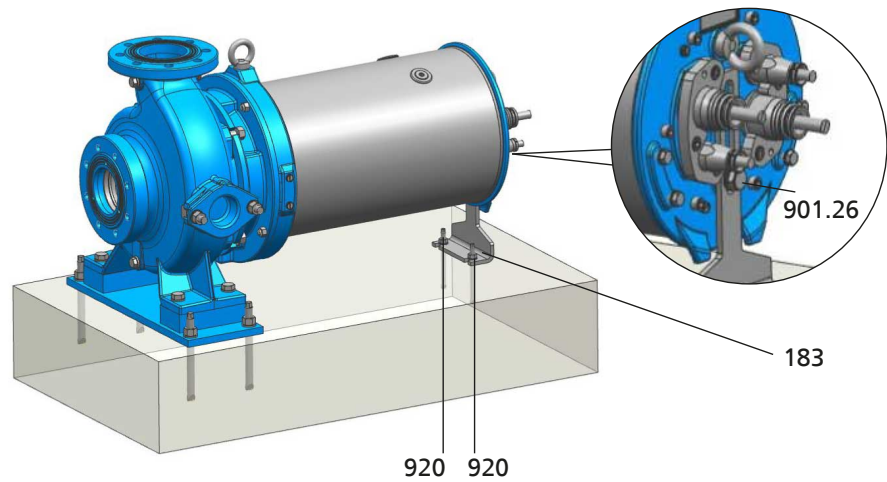

**Fig. 3:** Installed pump set / Removing the support foot

- ✓ The pump set has been installed as shown.
  - ✓ The suction-side and discharge-side piping has been connected to the pump.
  - ✓ The (optional) flanged spacer has been fitted on the suction side.
1. Undo nut 920<sup>2)</sup> from both chemical anchors at support foot 183.
  2. Undo hexagon head bolt 901.26 at the motor cover.
  3. Remove support foot 183.

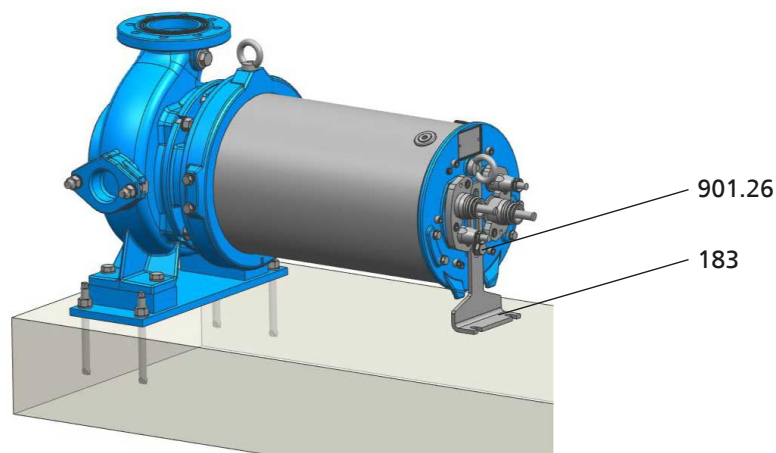
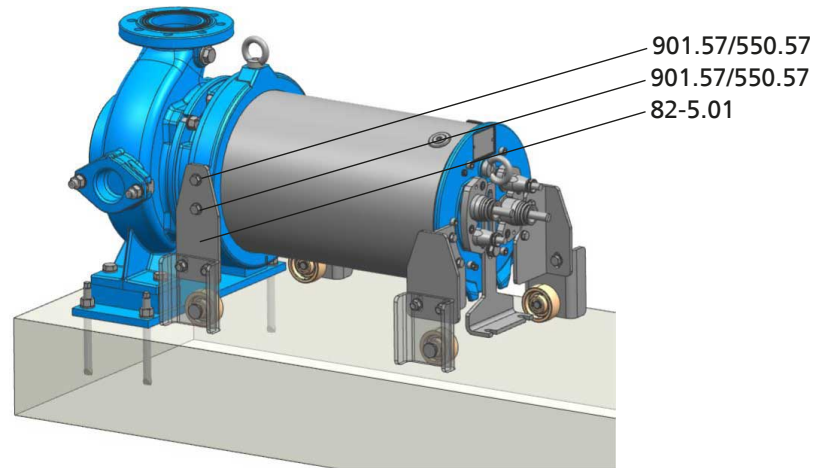

**Fig. 4:** Positioning the support foot

4. Position support foot 183 as shown.
5. Position hexagon head bolt 901.26 at the motor cover but do not tighten it yet.

2) Component part of chemical anchor, not included in maintenance aid scope of supply





**Fig. 5:** Fitting the pump-end adapters on both sides

6. Tighten hexagon head bolts/discs 901.57/550.57 at both adapters 82-5.01.

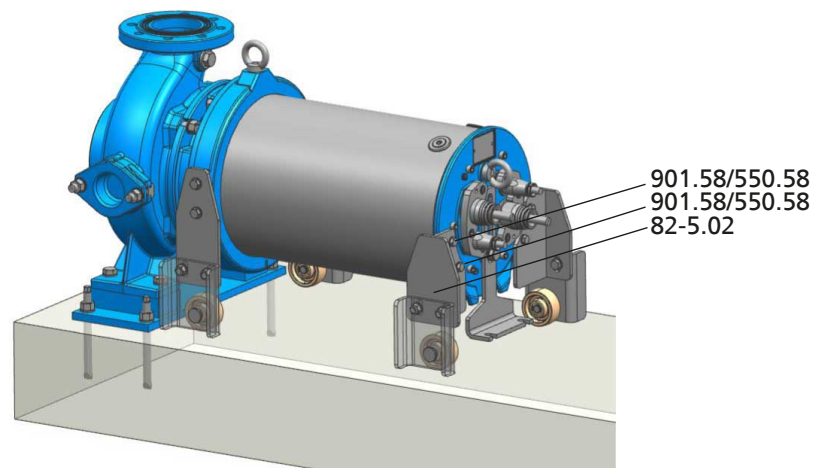

**Fig. 6:** Fitting the motor-end adapters on both sides

7. Tighten hexagon head bolts/discs 901.58/550.58 at both adapters 82-5.02.

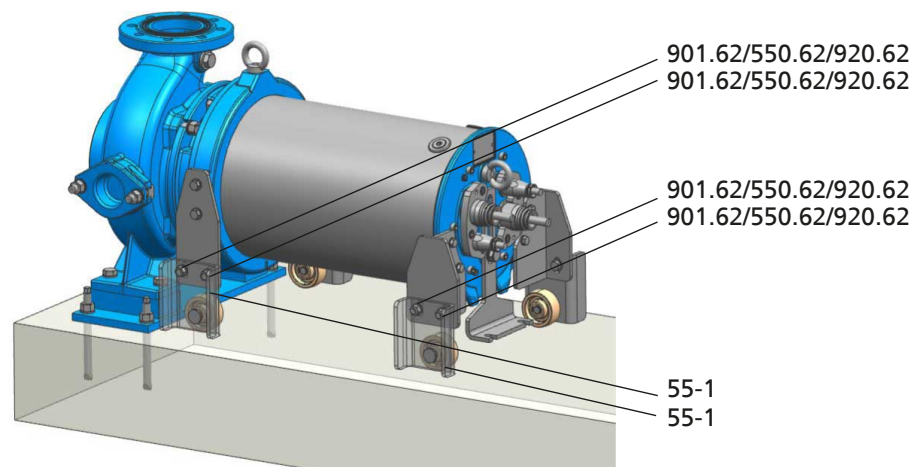

**Fig. 7:** Positioning the guide plates with rollers on both sides

8. Position hexagon head bolts/nuts 901.62/550.62/920.62 at the four guide plates 55-1 but do not tighten them yet.

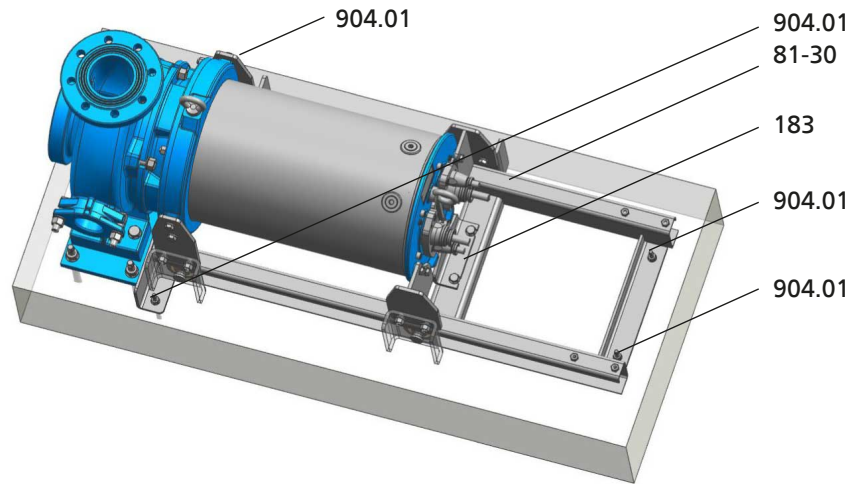

**Fig. 8:** Preparing guide rail installation (⇒ Section 8.2, Page 27) / chemical anchors

9. Position guide rails 81-30 underneath the motor such that they run parallel to the (pump-end/motor-end) adapters / parallel to the motor centreline and align with support foot 183.
10. Mark the four fastening points for chemical anchors 904.01.
11. Remove guide rails 81-30 again.
12. Drill four holes for chemical anchors 904.01 in accordance with the "Chemical anchor dimensions" table. Then clean the holes.

	<p><b>⚠ WARNING</b></p>
	<p><b>Improper handling of mortar cartridge</b> Skin sensitisation and/or irritation!</p> <p>▷ Wear suitable protective clothing.</p>

13. Insert the mortar cartridges into the four holes drilled for chemical anchors 904.01. Observe the curing times of the mortar cartridges!
14. Drive threaded rods into the four holes drilled for chemical anchors 904.01 using an impact drill or hammer drill.

Chemical anchor dimensions

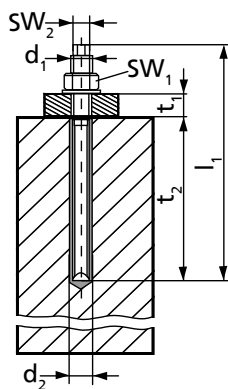

**Fig. 9:** Dimensions

**Table 6:** Chemical anchor dimensions

Size ( $d_1 \times l_1$ )	$d_2$	$t_1$	$t_2$	$SW_1^{3)}$	$SW_2^{3)}$	$M_{d1}$
	[mm]					[Nm]
M10 × 130	12	22	90	17	6	20
M12 × 160	14	25	110	19	8	40
M16 × 190	18	35	125	24	12	60
M20 × 260	25	65	170	30	14	120

Size (d <sub>1</sub> × l <sub>1</sub> )	d <sub>2</sub>	t <sub>1</sub>	t <sub>2</sub>	SW <sub>1</sub> <sup>3)</sup>	SW <sub>2</sub> <sup>3)</sup>	M <sub>d1</sub>
	[mm]					[Nm]
M24 × 300 <sup>4)</sup>	28	65	210	36	17	180
M30 × 380 <sup>4)</sup>	35	65	280	46	-	400

**Table 7:** Curing times of mortar cartridge

Floor temperature [°C]	Curing time [min]
-5 to 0	240
0 to +10	45
+10 to +20	20
> +20	10

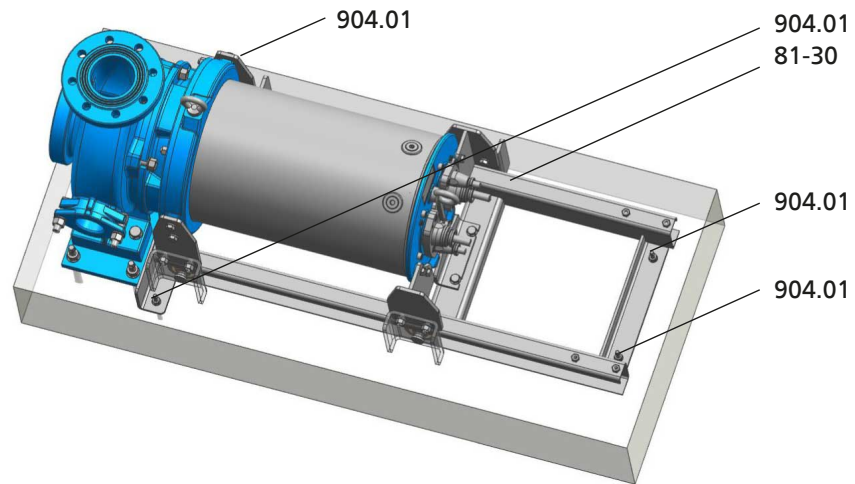

**Fig. 10:** Positioning the guide rails / Fitting the chemical anchors

15. Position guide rails 81-30.
16. After the curing time specified in the "Curing times of mortar cartridge" table, tighten the nuts of the four chemical anchors 904.01 evenly.

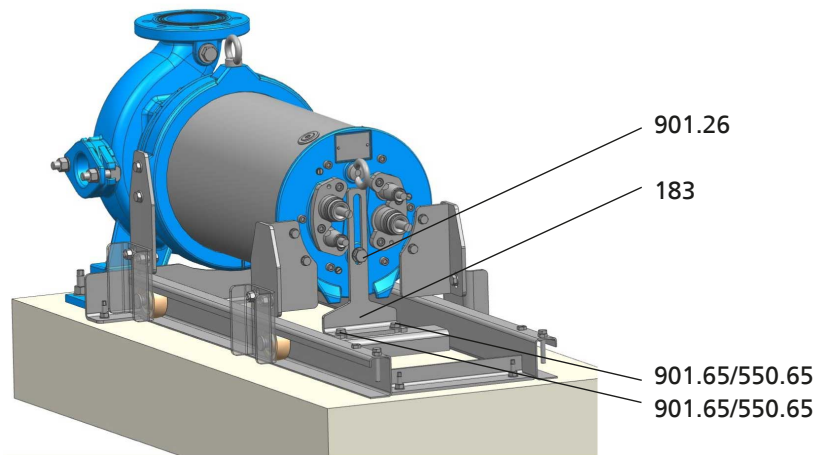
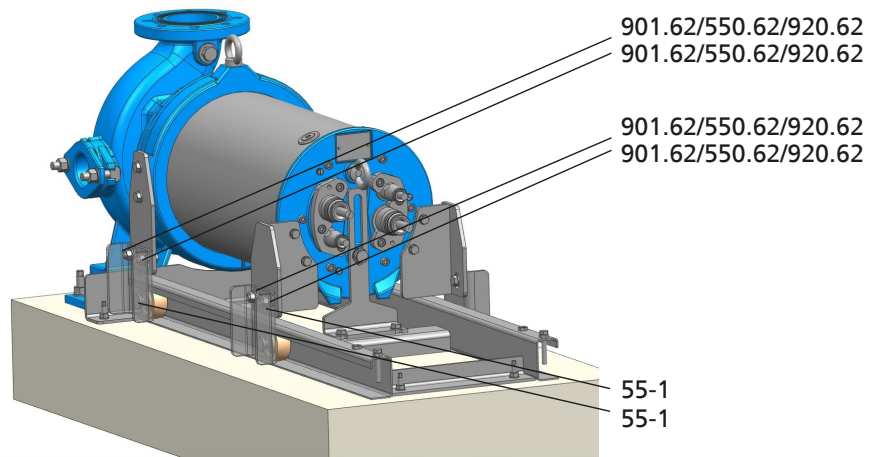

**Fig. 11:** Fitting the support foot

17. Tighten hexagon head bolts 901.65/550.65 at support foot 183.
18. Tighten hexagon head bolt 901.26 at the motor cover.

2553.870/01-EN

3) SW = Width across flats  
 4) Mounting accessories of the respective manufacturer are required.



**Fig. 12:** Fitting the guide plates with rollers on both sides

19. Tighten hexagon head bolts 901.62/550.62/920.62 at the four guide plates 55-1.

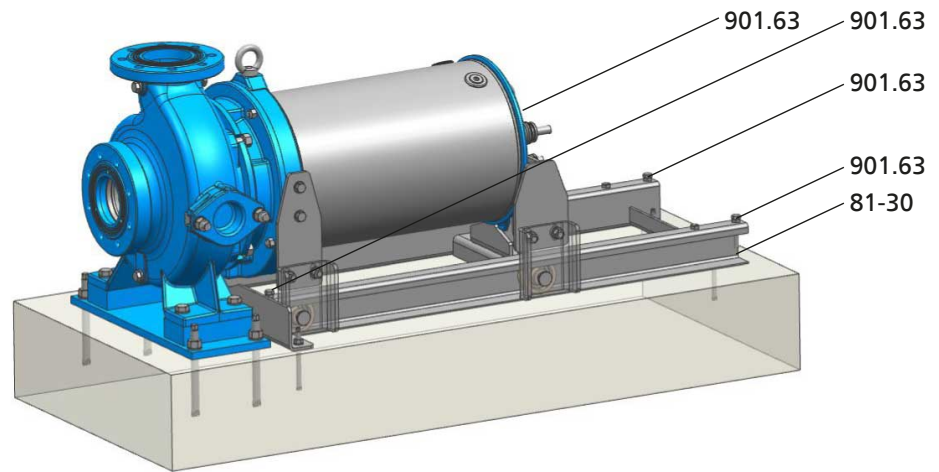

**Fig. 13:** Fitting the guide rails on both sides

20. Tighten hexagon head bolts 901.63 at guide rails 81-30.

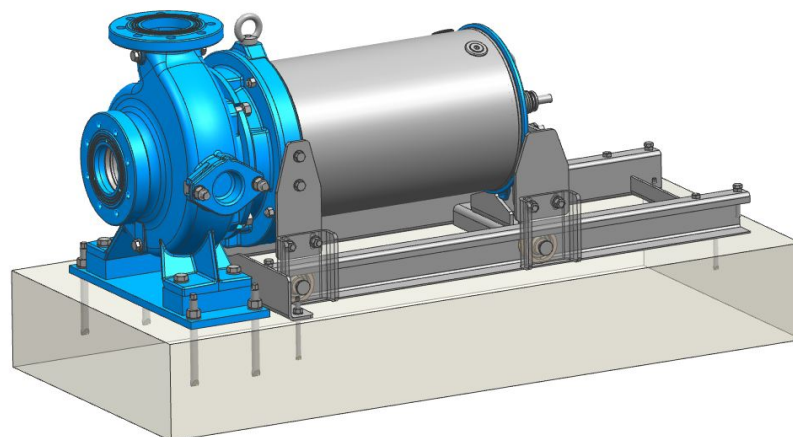



**Fig. 14:** Pump set with maintenance aid in operating position

The AmaSlide maintenance aid is ready for operation, and the pump set is in operating position.

## 6 Operation

### 6.1 Safety regulations

	<div style="background-color: #e67e22; color: white; padding: 5px;"><b>⚠ DANGER</b></div> <p><b>Insufficient preparation of work on the pump (set)</b> Risk of injury!</p> <ul style="list-style-type: none"> <li>▷ Properly shut down the pump set.</li> <li>▷ Close the shut-off elements in the suction line and discharge line.</li> <li>▷ Drain the pump and release the pump pressure.</li> <li>▷ Shut off any auxiliary feed lines.</li> <li>▷ Allow the pump set to cool down to ambient temperature.</li> </ul>
	<div style="background-color: #f1c40f; color: white; padding: 5px;"><b>⚠ WARNING</b></div> <p><b>Components with sharp edges</b> Risk of cutting or shearing injuries!</p> <ul style="list-style-type: none"> <li>▷ Always use appropriate caution for installation and dismantling work.</li> <li>▷ Wear work gloves.</li> </ul>
	<div style="background-color: #f1c40f; color: white; padding: 5px;"><b>⚠ WARNING</b></div> <p><b>Unintentional starting of the pump set</b> Risk of injury by moving components and shock currents!</p> <ul style="list-style-type: none"> <li>▷ Ensure that the pump set cannot be started unintentionally.</li> <li>▷ Always make sure the electrical connections are disconnected before carrying out work on the pump set.</li> </ul>

6.2 Moving the maintenance aid into servicing position

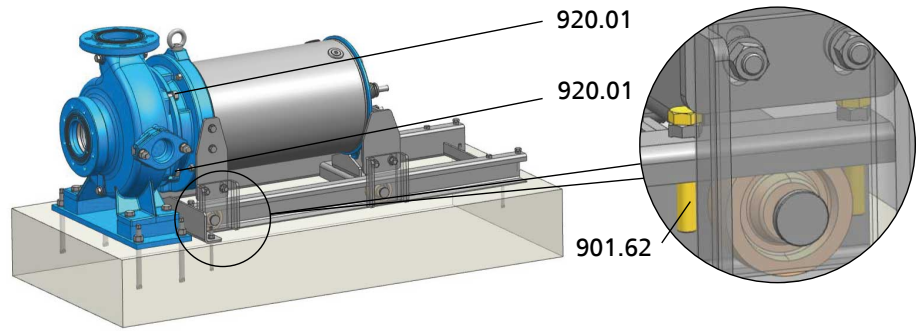

Fig. 15: Operating position

- ✓ The pump set is in operating position.
  - ✓ The pump set has been shut down.
  - ✓ All safety regulations have been observed. (⇒ Section 6.1, Page 21)
1. Undo and remove hexagon head bolts 901.62 at the pump end.
  2. Undo nuts 920.01 at the pump set.

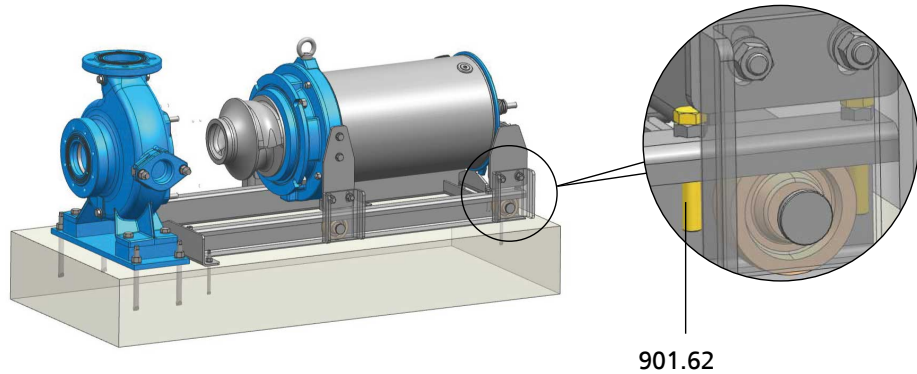

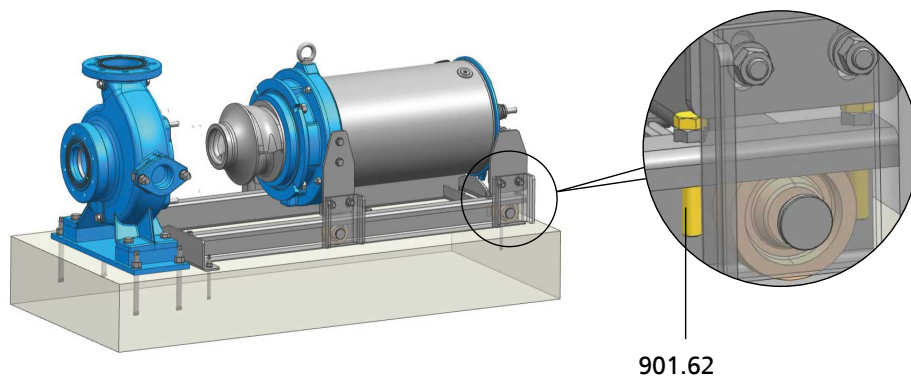

Fig. 16: Servicing position

3. Guide the back pull-out unit including motor along the guide rails as far as it will go.
  4. Fit hexagon head bolts 901.62 in their new position in front of the motor-end roller and tighten them.
- ⇒ The back pull-out unit including motor is now secured on the guide rails in servicing position.

	<p><b>⚠ WARNING</b></p>
	<p><b>Work on unsecured maintenance aid</b> Risk of crushing injuries!</p> <p>▷ Never perform any maintenance/servicing work before the maintenance aid has been secured in servicing position.</p>

### 6.3 Moving the maintenance aid into operating position



**Fig. 17:** Servicing position

✓ The pump set is in servicing position.

1. Undo and remove hexagon head bolts 901.62 at the motor end.
2. Guide the back pull-out unit including motor along the guide rails until it abuts the pump casing.  
The force required to move the back pull-out unit depends on the motor weight.

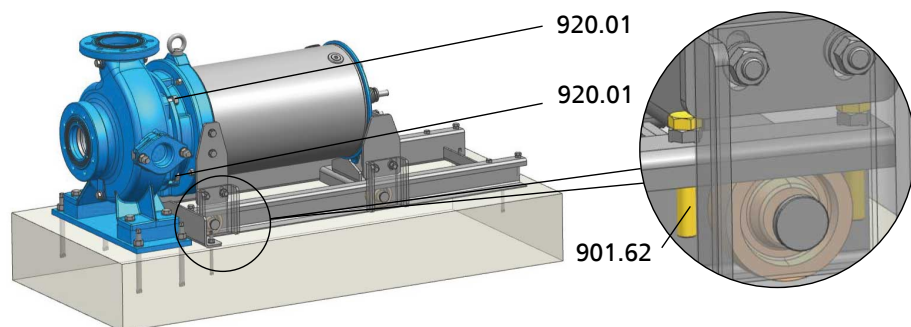

**Fig. 18:** Operating position

3. Tighten nuts 920.01 at the pump set.
  4. Fit hexagon head bolts 901.62 in their new position in front of the pump-end roller and tighten them.
- ⇒ The pump set is in operating position and can be returned to service.

## 7 Servicing/Maintenance

### 7.1 Safety regulations

The operator ensures that maintenance, inspection and installation are performed by authorised, qualified specialist personnel who are thoroughly familiar with the manual.

	<b>⚠ WARNING</b>
	<p><b>Fluids and supplies posing a health hazard and/or hot fluids and supplies</b> Risk of injury!</p> <ul style="list-style-type: none"> <li>▷ Observe all relevant laws.</li> <li>▷ Decontaminate maintenance aids or pump sets including maintenance aid which have been used in fluids posing a health hazard.</li> <li>▷ When handling hazardous fluids take appropriate measures to protect persons and the environment.</li> </ul>

	<b>NOTE</b>
	<p>All maintenance work, service work and installation work can be carried out by KSB Service or authorised workshops. For contact details please refer to the enclosed "Addresses" booklet or visit "<a href="http://www.ksb.com/contact">www.ksb.com/contact</a>" on the Internet.</p>

Never use force when dismantling and reassembling the maintenance aid.

	<b>CAUTION</b>
	<p><b>Use of impermissible spare parts</b> Damage to the machinery!</p> <ul style="list-style-type: none"> <li>▷ Never use spare parts which do not meet the technical requirements.</li> </ul>

### 7.2 Maintenance/inspection

The maintenance aid is maintenance-free!

When performing maintenance/servicing or inspection work on the pump set, also perform a visual inspection of all parts of the maintenance aid and check that all bolted/screwed connections are tightened firmly. (⇒ Section 7.4, Page 25)

### 7.3 Cleaning

	<b>⚠ WARNING</b>
	<p><b>Fluids handled, consumables and supplies which are hot and/or pose a health hazard</b> Hazard to persons and the environment!</p> <ul style="list-style-type: none"> <li>▷ Collect and properly dispose of flushing fluid and any fluid residues.</li> <li>▷ Wear safety clothing and a protective mask if required.</li> <li>▷ Observe all legal regulations on the disposal of fluids posing a health hazard.</li> </ul>

If the maintenance aid and/or pump set have been used in fluids whose residues could lead to corrosion damage in the presence of atmospheric humidity or could ignite upon contact with oxygen, the products must be flushed, neutralised and treated with anhydrous inert gas to ensure drying.



## 7.4 Tightening torques

**Table 8:** Tightening torques [Nm]

Thread	Torque (A4-70 / 1.4462)
M 10	35
M 12	60
M 16	150

## 7.5 Spare parts stock

### 7.5.1 Ordering spare parts

Always quote the following data when ordering replacement or spare parts:

Maintenance aid data:

- Order number
- Order item number
- Type series
- Size
- Year of construction
- Part number and description (⇒ Section 8.1, Page 26)

Pump set data:

- Order number
- Order item number
- Type series
- Size
- Motor size
- Year of construction

Refer to the name plate for all data.

Also specify the following data:

- Quantity of spare parts
- Shipping address
- Mode of dispatch (freight, mail, express freight, air freight)

## 8 Related Documents

### 8.1 General assembly drawings with list of components

#### 8.1.1 AmaSlide

Different designs are offered, depending on the pump.

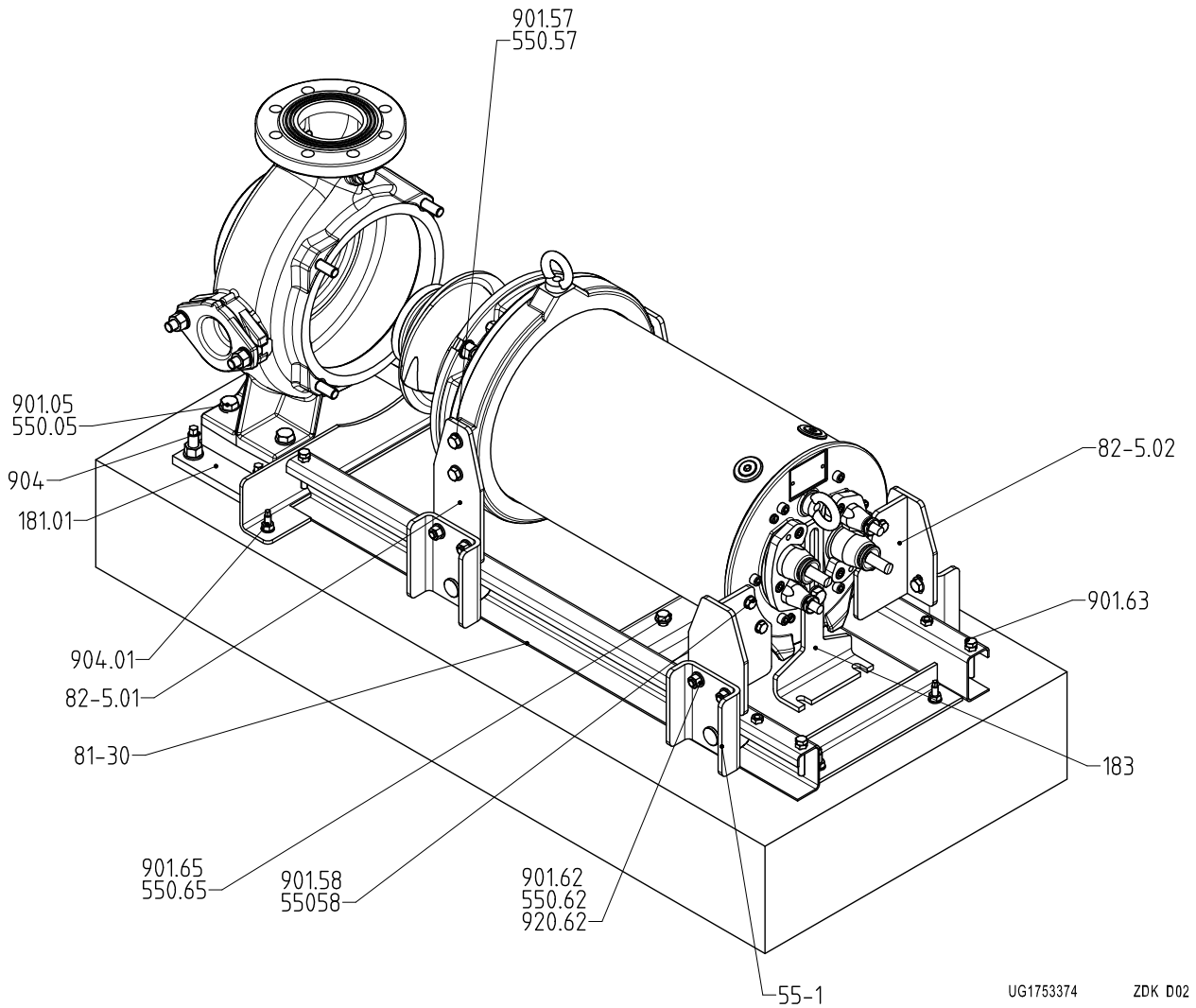
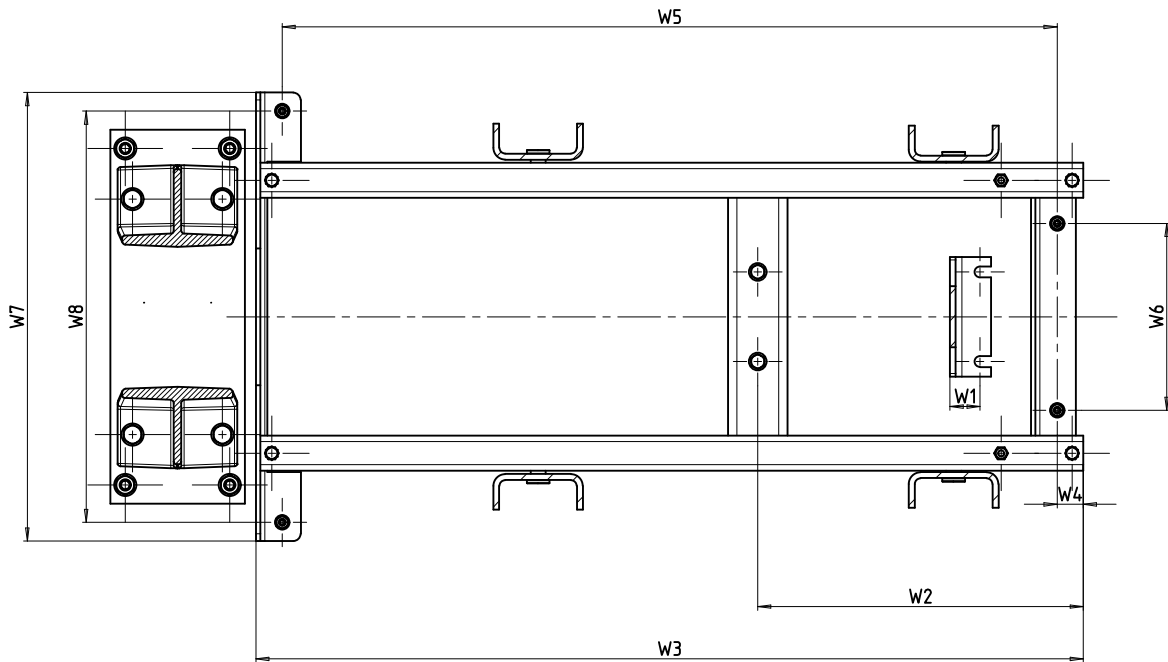

**Fig. 19:** General assembly drawing of AmaSlide maintenance aid for horizontally dry-installed KRT motor types KB16/18/22

**Table 9:** List of components

Part No.	Description	Part No.	Description
55-1	Guide plate with roller	550.05/.57/.58/.62/.65	Disc
81-30	Guide rail	901.05/.57/.58/.62/.63/.65	Hexagon head bolt
82-5.01	Adapter, pump end	904	Chemical anchor, pump
82-5.02	Adapter, motor end	904.01	Chemical anchor, maintenance aid
181.01	Pump stool	920.62	Nut
183	Support foot		

### 8.2 Combinations of pump and maintenance aid



UG1753374

ZDK D01

Fig. 20: AmaSlide dimensions

Table 10: Combinations of pumps and maintenance aids, including dimensions and weights

Size	Impeller type	Locating fit diameter	Shaft centreline height	Motor	[kg]	Dimensions [mm]							
						W1	W2	W3	W4	W5	W6	W7	W8
040-252	F	250	280 <sup>5)</sup>	KB16	32	40	435	1106	35	1036	250	600	550
040-252	K	250	280 <sup>5)</sup>	KB16	32	40	435	1106	35	1036	250	600	550
080-252	F	250	280 <sup>5)</sup>	KB16	32	40	435	1106	35	1036	250	600	550
080-253	F	250	280 <sup>5)</sup>	KB16	32	40	435	1106	35	1036	250	600	550
080-253	E	250	280 <sup>5)</sup>	KB16	32	40	435	1106	35	1036	250	600	550
080-253	K	250	280 <sup>5)</sup>	KB16	32	40	435	1106	35	1036	250	600	550
100-253	E	250	280 <sup>5)</sup>	KB16	32	40	435	1106	35	1036	250	600	550
100-253	K	250	280 <sup>5)</sup>	KB16	32	40	435	1106	35	1036	250	600	550
100-254	F	250	280 <sup>5)</sup>	KB16	32	40	435	1106	35	1036	250	600	550
100-254	K	250	280 <sup>5)</sup>	KB16	32	40	435	1106	35	1036	250	600	550
100-253	D	250	280	KB16	32	40	435	1106	35	1036	250	600	550
150-253	D	250	280	KB16	32	40	435	1106	35	1036	250	600	550
080-317	F	315	280 <sup>5)</sup>	KB16	32	40	435	1106	35	1036	250	600	550
080-315	K	315	280 <sup>5)</sup>	KB16	32	40	435	1106	35	1036	250	600	550
080-315	D	315	280	KB16	32	40	435	1106	35	1036	250	600	550
080-316	D	315	280	KB16	32	40	435	1106	35	1036	250	600	550
080-317	D	315	280	KB16	32	40	435	1106	35	1036	250	600	550
100-315	D	315	280	KB16	32	40	435	1106	35	1036	250	600	550
100-316	D	315	280	KB16	32	40	435	1106	35	1036	250	600	550

5) With pump stool

Size	Impeller type	Locating fit diameter	Shaft centreline height	Motor	[kg]	Dimensions [mm]							
						W1	W2	W3	W4	W5	W6	W7	W8
100-316	F	315	280	KB16	32	40	435	1106	35	1036	250	600	550
100-316	K	315	280	KB16	32	40	435	1106	35	1036	250	600	550
100-317	E	315	280 <sup>5)</sup>	KB16	32	40	435	1106	35	1036	250	600	550
150-315	D	315	315	KB16	32	40	435	1106	35	1036	250	600	550
150-315	F	315	280	KB16	32	40	435	1106	35	1036	250	600	550
150-317	E	315	280	KB16	32	40	435	1106	35	1036	250	600	550
150-317	K	315	280	KB16	32	40	435	1106	35	1036	250	600	550
200-315	D	315	375	KB16	32	40	435	1106	35	1036	250	600	550
200-315	K	315	315	KB16	32	40	435	1106	35	1036	250	600	550
200-316	K	315	315	KB16	32	40	435	1106	35	1036	250	600	550
200-317	K	315	315	KB16	32	40	435	1106	35	1036	250	600	550
200-318	K	315	315	KB16	32	40	435	1106	35	1036	250	600	550
080-317	F	315	280 <sup>5)</sup>	KB18	48	40	470	1306	35	1236	270	680	630
080-315	K	315	280 <sup>5)</sup>	KB18	48	40	470	1306	35	1236	270	680	630
080-315	D	315	280	KB18	48	40	470	1306	35	1236	270	680	630
080-317	D	315	280	KB18	48	40	470	1306	35	1236	270	680	630
100-315	D	315	280	KB18	48	40	470	1306	35	1236	270	680	630
100-316	D	315	280	KB18	48	40	470	1306	35	1236	270	680	630
100-316	F	315	280	KB18	48	40	470	1306	35	1236	270	680	630
100-316	K	315	280	KB18	48	40	470	1306	35	1236	270	680	630
100-317	E	315	280 <sup>5)</sup>	KB18	48	40	470	1306	35	1236	270	680	630
150-315	D	315	315	KB18	48	40	470	1306	35	1236	270	680	630
150-315	F	315	280	KB18	48	40	470	1306	35	1236	270	680	630
150-317	E	315	280	KB18	48	40	470	1306	35	1236	270	680	630
150-317	K	315	280	KB18	48	40	470	1306	35	1236	270	680	630
200-315	D	315	375	KB18	48	40	470	1306	35	1236	270	680	630
200-315	K	315	315	KB18	48	40	470	1306	35	1236	270	680	630
200-316	K	315	315	KB18	48	40	470	1306	35	1236	270	680	630
200-317	K	315	315	KB18	48	40	470	1306	35	1236	270	680	630
200-318	K	315	315	KB18	48	40	470	1306	35	1236	270	680	630
080-317	F	315	280 <sup>5)</sup>	KB22	53,5	50	560	1506	35	1436	361	760	710
080-315	K	315	280 <sup>5)</sup>	KB22	53,5	50	560	1506	35	1436	361	760	710
080-315	D	315	280	KB22	53,5	50	560	1506	35	1436	361	760	710
100-315	D	315	280	KB22	53,5	50	560	1506	35	1436	361	760	710
100-316	D	315	280	KB22	53,5	50	560	1506	35	1436	361	760	710
100-316	F	315	280	KB22	53,5	50	560	1506	35	1436	361	760	710
100-316	K	315	280	KB22	53,5	50	560	1506	35	1436	361	760	710
100-317	E	315	280 <sup>5)</sup>	KB22	53,5	50	560	1506	35	1436	361	760	710
150-315	D	315	315	KB22	53,5	50	560	1506	35	1436	361	760	710
150-315	F	315	280	KB22	53,5	50	560	1506	35	1436	361	760	710
150-317	E	315	280	KB22	53,5	50	560	1506	35	1436	361	760	710
150-317	K	315	280	KB22	53,5	50	560	1506	35	1436	361	760	710
200-315	D	315	375	KB22	53,5	50	560	1506	35	1436	361	760	710
200-315	K	315	315	KB22	53,5	50	560	1506	35	1436	361	760	710
200-316	K	315	315	KB22	53,5	50	560	1506	35	1436	361	760	710
200-317	K	315	315	KB22	53,5	50	560	1506	35	1436	361	760	710
200-318	K	315	315	KB22	53,5	50	560	1506	35	1436	361	760	710

Size	Impeller type	Locating fit diameter	Shaft centreline height	Motor	[kg]	Dimensions [mm]							
						W1	W2	W3	W4	W5	W6	W7	W8
100-400	K	410	315	KB18	48	40	470	1306	35	1236	270	680	630
100-401	K	410	315	KB18	48	40	470	1306	35	1236	270	680	630
100-401	F	410	315	KB18	48	40	470	1306	35	1236	270	680	630
100-401	E	410	315	KB18	48	40	470	1306	35	1236	270	680	630
150-400	D	410	315	KB18	48	40	470	1306	35	1236	270	680	630
150-400	K	410	355	KB18	48	40	470	1306	35	1236	270	680	630
150-401	E	410	355	KB18	48	40	470	1306	35	1236	270	680	630
150-401	F	410	355	KB18	48	40	470	1306	35	1236	270	680	630
150-403	K	410	355	KB18	48	40	470	1306	35	1236	270	680	630
151-403	K	410	355	KB18	48	40	470	1306	35	1236	270	680	630
200-400	D	410	355	KB18	48	40	470	1306	35	1236	270	680	630
200-401	E	410	355	KB18	48	40	470	1306	35	1236	270	680	630
200-402	K	410	375	KB18	48	40	470	1306	35	1236	270	680	630
200-403	K	410	375	KB18	48	40	470	1306	35	1236	270	680	630
250-400	D	410	455	KB18	48	40	470	1306	35	1236	270	680	630
250-401	K	410	425	KB18	48	40	470	1306	35	1236	270	680	630
250-403	K	410	425	KB18	48	40	470	1306	35	1236	270	680	630
300-400	D	410	450	KB18	48	40	470	1306	35	1236	270	680	630
300-400	K	410	450	KB18	48	40	470	1306	35	1236	270	680	630
300-401	K	410	450	KB18	48	40	470	1306	35	1236	270	680	630
300-403	K	410	450	KB18	48	40	470	1306	35	1236	270	680	630
100-400	K	410	315	KB22	53,5	50	560	1506	35	1436	361	760	710
100-401	K	410	315	KB22	53,5	50	560	1506	35	1436	361	760	710
100-401	F	410	315	KB22	53,5	50	560	1506	35	1436	361	760	710
100-401	E	410	315	KB22	53,5	50	560	1506	35	1436	361	760	710
150-400	D	410	315	KB22	53,5	50	560	1506	35	1436	361	760	710
150-400	K	410	355	KB22	53,5	50	560	1506	35	1436	361	760	710
150-401	E	410	355	KB22	53,5	50	560	1506	35	1436	361	760	710
150-401	F	410	355	KB22	53,5	50	560	1506	35	1436	361	760	710
150-403	K	410	355	KB22	53,5	50	560	1506	35	1436	361	760	710
151-403	K	410	355	KB22	53,5	50	560	1506	35	1436	361	760	710
200-400	D	410	355	KB22	53,5	50	560	1506	35	1436	361	760	710
200-401	E	410	355	KB22	53,5	50	560	1506	35	1436	361	760	710
200-402	K	410	375	KB22	53,5	50	560	1506	35	1436	361	760	710
200-403	K	410	375	KB22	53,5	50	560	1506	35	1436	361	760	710
250-400	D	410	455	KB22	53,5	50	560	1506	35	1436	361	760	710
250-401	K	410	425	KB22	53,5	50	560	1506	35	1436	361	760	710
250-403	K	410	425	KB22	53,5	50	560	1506	35	1436	361	760	710
300-400	D	410	450	KB22	53,5	50	560	1506	35	1436	361	760	710
300-400	K	410	450	KB22	53,5	50	560	1506	35	1436	361	760	710
300-401	K	410	450	KB22	53,5	50	560	1506	35	1436	361	760	710
300-403	K	410	450	KB22	53,5	50	560	1506	35	1436	361	760	710

2553.870/01-EN

## 9 Certificate of Decontamination

Type: .....

Order number/ .....

Order item number<sup>6)</sup>: .....

Delivery date: .....

Applications: .....

Fluid handled<sup>6)</sup>: .....

Please tick where applicable<sup>6)</sup>:



Corrosive



Oxidising



Flammable



Explosive



Hazardous to health



Seriously hazardous to health



Toxic



Radioactive



Bio-hazardous



Safe

Reason for return<sup>6)</sup>: .....

Comments: .....

The product/accessories have been carefully drained, cleaned and decontaminated inside and outside prior to dispatch/ placing at your disposal.

We herewith declare that this product is free from hazardous chemicals, biological and radioactive substances.

For mag-drive pumps, the inner rotor unit (impeller, casing cover, bearing ring carrier, plain bearing, inner rotor) has been removed from the pump and cleaned. In cases of containment shroud leakage, the outer rotor, bearing bracket lantern, leakage barrier and bearing bracket or intermediate piece have also been cleaned.

For canned motor pumps, the rotor and plain bearing have been removed from the pump for cleaning. In cases of leakage at the stator can, the stator space has been examined for fluid leakage; if fluid handled has penetrated the stator space, it has been removed.

- No special safety precautions are required for further handling.
- The following safety precautions are required for flushing fluids, fluid residues and disposal:

.....

.....

We confirm that the above data and information are correct and complete and that dispatch is effected in accordance with the relevant legal provisions.

.....  
Place, date and signature

.....  
Address

.....  
Company stamp

6) Required fields

## Index

### C

Certificate of Decontamination 30

### D

Designation 13

Disposal 12

### E

Event of damage 6

Ordering spare parts 25

### I

Installation at site 15

### K

Key to safety symbols/markings 6

### M

Maintenance 24

### O

Other applicable documents 6

### P

Personnel 8

### Q

Qualifications 8

### R

Return to supplier 11

### S

Safety 8

Safety awareness 9

Scope of supply 14

Spare part

Ordering spare parts 25

Specialist technical personnel 8

Storage 11

### T

Tightening torques 25

Training 8

### W

Warnings 6

Warranty claims 6



**KSB SE & Co. KGaA**

Johann-Klein-Straße 9 • 67227 Frankenthal (Germany)

Tel. +49 6233 86-0

[www.ksb.com](http://www.ksb.com)

2553.870/01-EN (05040252)